

INSTALLATION INSTRUCTIONS AND OWNER'S MANUAL

Installer: Leave this manual with the appliance.
Consumer: Retain this manual for future reference.

⚠ WARNING

FIRE OR EXPLOSION HAZARD

Failure to follow safety warnings exactly could result in serious injury, death or property damage.

- Do not store or use gasoline or other flammable vapors and liquids in the vicinity of this or any other appliance.
- **WHAT TO DO IF YOU SMELL GAS**
 - Do not try to light any appliance.
 - Do not touch any electrical switch; do not use any phone in your building.
 - Leave the building immediately.
 - Immediately call your gas supplier from a neighbor's phone. Follow the gas supplier's instructions.
 - If you cannot reach your gas supplier, call the fire department.
- Installation and service must be performed by a qualified installer, service agency or the gas supplier.

**DIRECT VENT GAS
FIREPLACE INSERT**
TRADITIONAL MODELS
DXT(30,35)IN91(N,P)-2
UL FILE NO. MH 30033



This appliance may be installed in an aftermarket, permanently located, manufactured home (USA only) or mobile home, where not prohibited by state or local codes.

This appliance is only for use with the type of gas indicated on the rating plate. This appliance is not convertible for use with other gases, unless a certified kit is used.

⚠ WARNING

If not installed, operated and maintained in accordance with the manufacturer's instructions, this product could expose you to substances in fuel or from fuel combustion which can cause death or serious illness.

⚠ WARNING



**HOT GLASS WILL
CAUSE BURNS.
DO NOT TOUCH GLASS
UNTIL COOLED.
NEVER ALLOW CHILDREN
TO TOUCH GLASS.**

A barrier designed to reduce the risk of burns from the hot viewing glass is provided with this appliance and shall be installed for the protection of children and other at-risk individuals.



We suggest that our gas hearth products be installed and serviced by professionals who are certified in the U.S. by the National Fireplace Institute® (NFI) as NFI Gas Specialists.

BEFORE YOU START

1. Read the safety information on Pages 39 - 40.
2. Install the wiring. See page 25.
3. Install the venting. See pages 9 - 11.
4. Install the fireplace. See pages 9 - 11.
5. Connect the gas. See page 8.
6. Install the logs. See pages 15 - 23.
7. Light the fireplace and troubleshoot. See page 24.
8. Install trim and other accessories. See page 5.
9. Show the homeowner how to operate the fireplace.
10. Show the homeowner how to do the basic maintenance.

CARTON CONTENTS

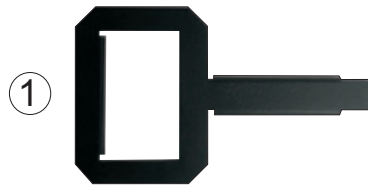

①

⑥



②

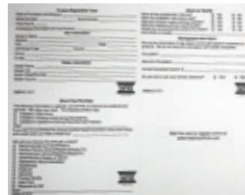

⑦



③

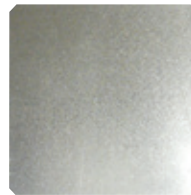

⑧



Index Number	Description	Quantity Supplied
1	Latch Tool	1
2	Product Registration Card	1
3	Label Plate	1
4	Warning Label	1
5	1/4-20 Bolt	1
6	Leveling Leg	4
7	AA Battery	2
8	AAA Battery	4
9	Rock Wool	1

④



⑨



⑤



See pages 36 to 37 for ordering repair parts.

TABLE OF CONTENTS

SECTION	PAGE
Introduction	4
Specifications & Accessories	5
Fireplace Insert Dimensions	6 - 7
Mantel and Trim Clearances	7
Gas Supply	8
Venting and Installation	9 - 11
Vertical Termination.....	12
Glass & Screen Assembly Removal	13
Glass & Screen Assembly Placement.....	14
Log Identification	15
Log Placement.....	16 - 23
Lighting Instructions	24
IPI System Wiring Diagram.....	25
Remote Control Operation Instructions.....	26 - 31
Insert Maintenance and Service	32
Blower Removal / Replacement.....	33 - 34
Maser Parts Distributors	35
How To Order Repair Parts	35
Parts List.....	36
Exploded View	37
Decorative Fronts.....	38
Important Safety Information.....	39
Safety Information for Users of LP-Gas	40
Warranty.....	41
Appliance Service History	42 -43

INTRODUCTION

Instructions to Installer

1. Installer must leave instruction manual with owner after installation.
 2. Installer must have owner fill out and mail product registration card supplied with the fireplace.
 3. Installer should show owner how to start and operate the insert.
- This direct vent gas fireplace heater is designed to operate with all combustion air being siphoned from the outside of the building and all exhaust gases expelled to the outside of the building. The information contained in this manual pertains to all models and gas control systems unless otherwise noted.

WARNING

This unit is not for use with solid fuels

Appliance Certification

This fireplace is design certified in accordance with American National Standard/CSA Standard ANSI Z.21-88/CSA 2.33 and by Underwriters Laboratories as a Direct Vent Gas Fireplace Heater and shall be installed according to these instructions.

Consult your local building code agency, prior to installation, to ensure compliance with local codes-including permits and inspections.

The fireplace insert, when installed, must be electrically grounded in accordance with local codes or, in absence of local codes, with the *National Electric Code ANSI/NFPA 70* or Canadian Electric code, CSA C22.1, if an external electrical source is utilized.

These models may be installed in a bedroom or bed-sitting room in the U.S.A. and Canada.

Qualified Installing Agency

Installation and replacement of gas piping, gas utilization equipment or accessories and repair and servicing of equipment shall be performed only by a qualified agency. The term "qualified agency" means any individual, firm, corporation or company which either in person or through a representative is engaged in and is responsible for (a) the installation or replacement of gas piping or (b) the connection, installation, repair or servicing of equipment, who is experienced in such work, familiar with all precautions required and has complied with all the requirements of the authority having jurisdiction.

Commonwealth of Massachusetts: The installation must be made by a licensed plumber or gas fitter in the Commonwealth of Massachusetts.

The installation must conform with local codes or, in the absence of local codes, with the *National Fuel Gas Code ANSI Z223.1/NFPA 54* Natural Gas and Propane Installation Code, or CSA B149.1 in Canada. *Available from the American National Standards Institute, Inc. 11 West 42nd St., New York, N.Y. 10036.*

WARNING

ANY CHANGE TO THIS FIREPLACE OR ITS CONTROLS CAN BE DANGEROUS.

Improper installation or use of the fireplace can cause serious injury or death from fire, burns, explosions, or carbon monoxide poisoning

Any alteration of the original design, installed other than as shown in these instructions or use with a type of gas not shown on the rating plate is the responsibility of the person and company making the change.

Important

All correspondence should refer to complete Model Number, Serial Number and type of gas.

High Altitude

When installing this unit at an elevation above 2000 feet (in the United States) it may be necessary to decrease the input rating by changing the existing burner orifice to a smaller size. Generally, input should be reduced 4 percent for each 1000 feet above sea level. However, if the heating value of the gas has been reduced, this general rule may not apply. Check with local gas utility for proper orifice size identification.

Canadian High Altitude

Altitude: 0-4500 feet (0-1370 m)

When installing this unit at an elevation above 4500 feet (in Canada), check with local authorities.

Consult your local gas utility for assistance in determining the proper orifice for location.

Preparation

This direct vent gas fireplace insert and its components are tested and safe when installed in accordance with this Installation Manual. Report to your dealer any parts damaged in shipment, specifically check glass condition. Do not install unit with damaged, incomplete, or substitute parts. Read all instructions before starting installation and follow these instructions carefully during installation to insure maximum benefit and safety. Failure to follow them will void your warranty and may present a fire hazard.

The warranty will be voided by, and the warranter disclaims any responsibility for the following actions:

- Installation of any damaged fireplace insert or vent system component.
- Modification of the fireplace insert or direct vent system.
- Installation other than as instructed by Empire Comfort Systems, Inc.
- Improper positioning of the logs or glass door assembly.
- Installation and/or use of any component part not manufactured or approved by manufacturer.

SPECIFICATIONS & ACCESSORIES

DXT30IN	LP	NAT
Input Btu/hr (Maximum)	26,000	30,000
Input Btu/hr (Minimum)	21,000	21,000
KWH (Maximum)	7.62	8.79
KWH (Minimum)	6.15	6.15
Orifice	#53	#36
Air Shutter Opening	FULL OPEN	1/4" OPEN
DXT35IN	LP	NAT
Input Btu/hr (Maximum)	30,000	35,000
Input Btu/hr (Minimum)	23,500	24,000
KWH (Maximum)	8.79	10.26
KWH (Minimum)	6.89	7.03
Orifice	1.65mm	#33
Air Shutter Opening	FULL OPEN	1/8" OPEN

SURROUNDS		
Model	Description	Used On
DS3066BL	3-Sided, 1 Piece, Matte Black	DXT30
DS3566BL	3-Sided, 1 Piece, Matte Black	DXT35

CERAMIC FIBER LINERS		
Model	Description	Used On
DVP30XAE	Aged Banded Brick	DXT30
DVP30XNE	Natural Banded Brick	DXT30
DVP30XN	New England Stack	DXT30
DVP30XS	Mountain Stack	DXT30
DVP30XWA	Aged Weave Brick	DXT30
DVP30XWT	Traditional Weave Brick	DXT30
DVP35XAE	Aged Banded Brick, 35-Inch	DXT35
DVP35XNE	Natural Banded Brick, 35-Inch	DXT35
DVP35XN	New England Stack, 35-Inch	DXT35
DVP35XS	Mountain Stack, 35-Inch	DXT35
DVP35XWA	Aged Weave Brick	DXT35
DVP35XWT	Traditional Weave Brick	DXT35

Conversion Kits	Description	Used On
37861	Conversion Kit, DV (Natural to Propane)	DXT30IN
31765	Conversion Kit, DV (Propane to Natural)	DXT30IN
37859	Conversion Kit, DV (Natural to Propane)	DXT35IN
31767	Conversion Kit, DV (Propane to Natural)	DXT35IN

Venting Kits	Description	Contents
DVKI2P	Vertical Vent Kit 17 1/2'	One piece of 35' FlexVent (split for 17 1/2' vent run), Round Cap, Flashing, connectors, and clamps. Recommended when installing to an existing round fireplace chimney pipe.
DVVK3FV	Vertical Vent Kit 25'	Two pieces of 25' FlexVent, Rectangle Cap, Flashing, connectors, and clamps Recommended when installing to a square or rectangular clay flue.
DVK35	Vent Extension Kit	35' flex vent extension section with 2 connectors and 4 clamps

NOTICE: When installing vent caps, special locally made flashings may be required to properly seal the vent system to the existing chimney termination.

DECORATIVE FRONTS		
Model	Description	Used On
DF30ABL	"Accord" - Black	DXT30IN
DF30AHP	"Accord" - Hammered Pewter	DXT30IN
DF30ASS	"Accord" - Stainless Steel	DXT30IN
DF30DHPBL	"Dunes" - Hammered Pewter and Black	DXT30IN
DF30DSSBL	"Dunes" - Stainless Steel and Black	DXT30IN
DF30VBL	"Veranda" - Black	DXT30IN
DF30VHP	"Veranda" - Hammered Pewter	DXT30IN
DF30VSS	"Veranda" - Stainless Steel	DXT30IN
DF30YBL	"Lafayette" - Black	DXT30IN
DF30YHP	"Lafayette" - Hammered Pewter	DXT30IN
DF30YSS	"Lafayette" - Stainless Steel	DXT30IN
DF35ABL	"Accord" - Black	DXT35IN
DF35AHP	"Accord" - Hammered Pewter	DXT35IN
DF35ASS	"Accord" - Stainless Steel	DXT35IN
DF35DHPBL	"Dunes" - Hammered Pewter and Black	DXT35IN
DF35DSSBL	"Dunes" - Stainless Steel and Black	DXT35IN
DF35VBL	"Veranda" - Black	DXT35IN
DF35VHP	"Veranda" - Hammered Pewter	DXT35IN
DF35VSS	"Veranda" - Stainless Steel	DXT35IN
DF35YBL	"Lafayette" - Black	DXT35IN
DF35YHP	"Lafayette" - Hammered Pewter	DXT35IN
DF35YSS	"Lafayette" - Stainless Steel	DXT35IN

REFLECTIVE LINERS		
Model	Description	Used On
DVP30KR	Black, 30-Inch	DXT30
DVP35KR	Black, 35-Inch	DXT35

FIREPLACE INSERT DIMENSIONS

When planning a fireplace insert installation, it's necessary to determine:

- The vent system configuration to be used.
- Gas supply piping.
- Electrical supply requirements.
- Proper opening size of fireplace required for installation of the fireplace insert.

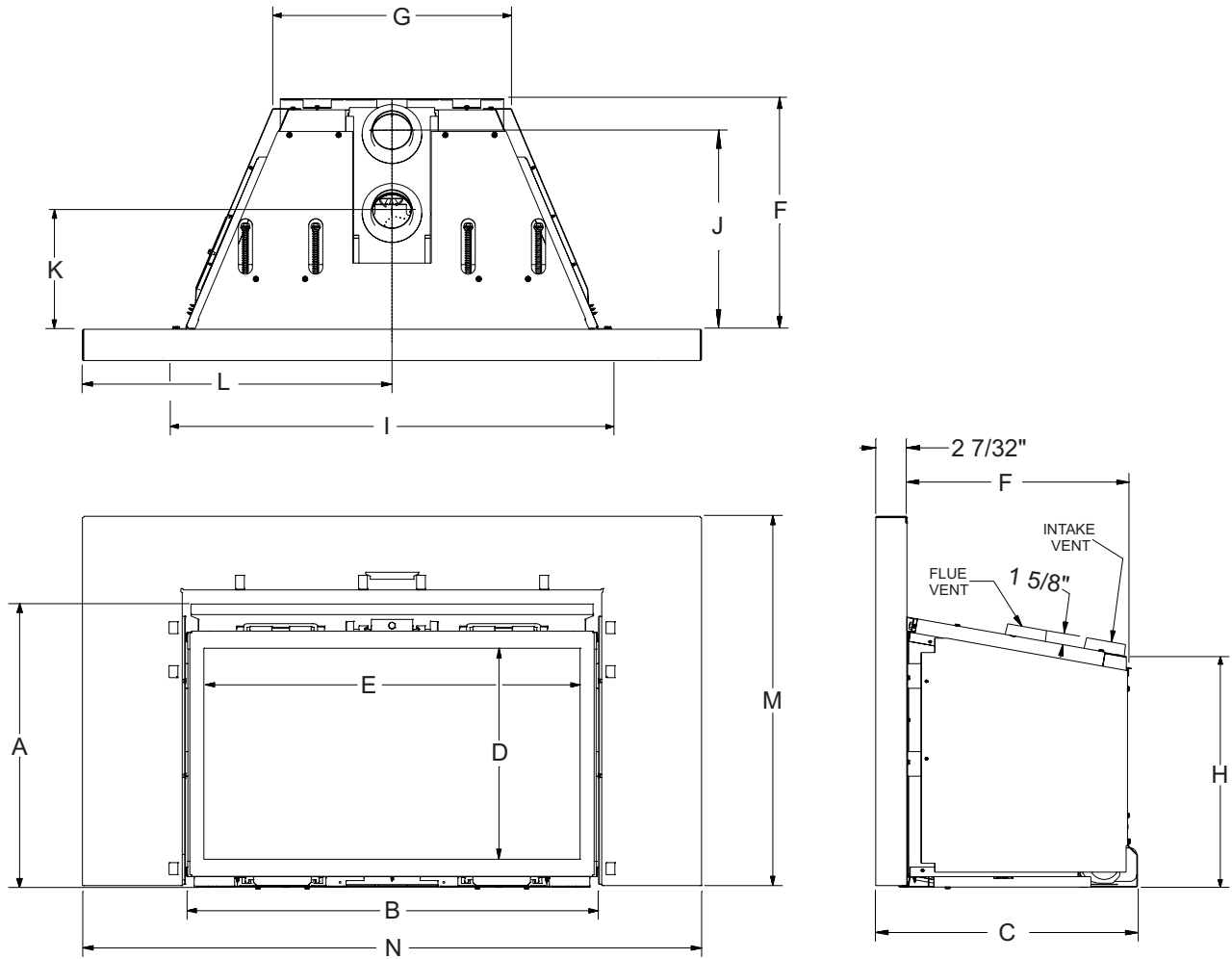

INSERT DIMENSIONS (in inches)		
DIMENSION	DXT30IN	DXT35IN
A	20-1/8	24-1/16
B	29-3/8	33-3/8
C	18-5/8	21-3/4
D	15	19
E	26-3/4	30-3/4
F	16-3/8	18-15/16
G	17	20-5/8
H	16-3/8	19-3/4
I	29-3/8	33-3/8
J	13-7/8	17-1/16
K	8-1/4	11-7/16
L	22	24
M	26-3/8	30-5/16
N	44	48

Figure 1

FIREPLACE INSERT DIMENSIONS

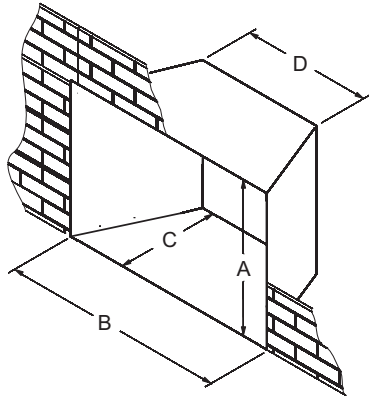

Fireplace Opening Dimensional Information/Sizing				
MINIMUM FIREPLACE OPENING DIMENSIONS (dimensions in inches)				
MODEL NO.	HEIGHT A*	FRONT WIDTH B	DEPTH C	REAR WIDTH D
DXT30IN	19-1/2	29-1/2	16-1/2	17-1/8
DXT35IN	23-9/16	33-1/2	19-5/8	20-3/4

Figure 2

MANTEL AND TRIM CLEARANCES

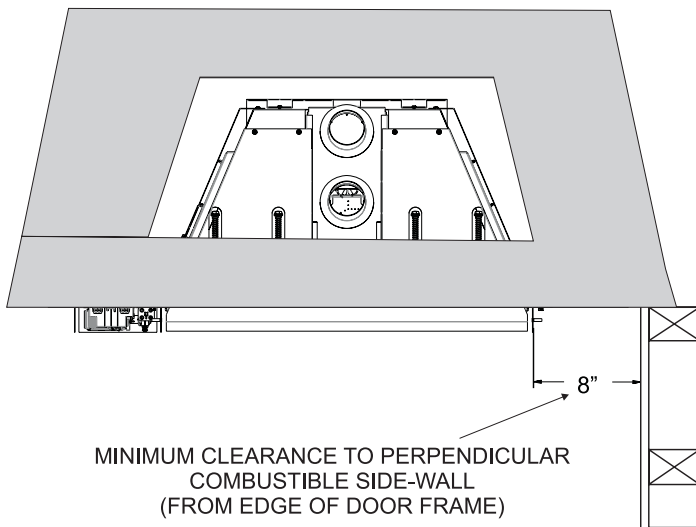
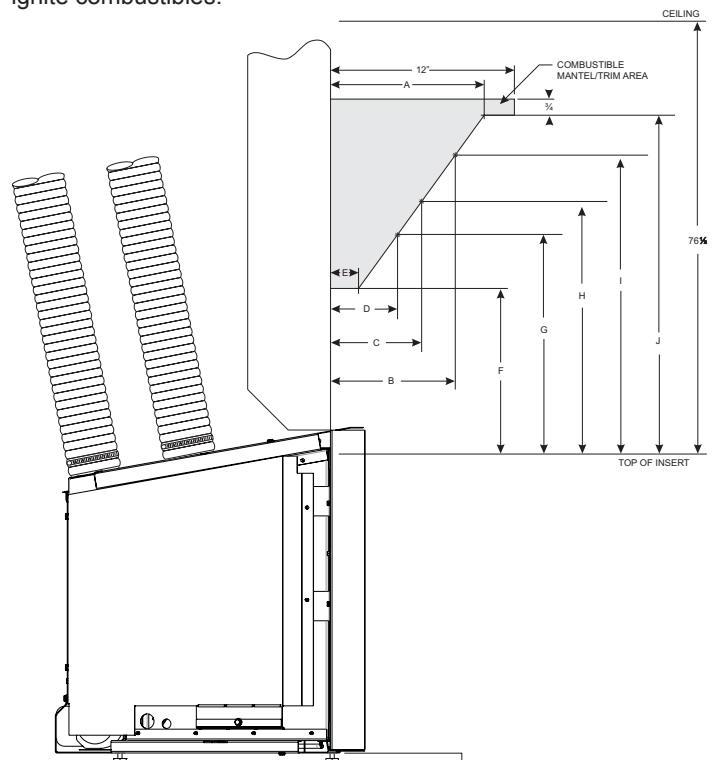

Figure 3

Combustible Material

No greeting cards, stockings or ornamentation of any type should be placed on or attached to the fireplace. The flow of heat can ignite combustibles.



Distance from Face of Fireplace (dimensions in inches)		Height Above Top of Insert (dimensions in inches)	
A	10	F	14
B	8	G	17-1/2
C	6	H	21-1/2
D	3	I	24-1/4
E	1/2	J	27

The minimum distance to the room ceiling from the Top of the Insert is 76-1/2.

Figure 4

GAS SUPPLY

The gas pipeline can be brought in through the right or left side of the appliance. The insert has a Flexline with shutoff valve located on the right side when facing the unit. **See Figures 5 and 6.** Consult the current National Fuel Gas Code, ANSI Z223.1 CAN/CGA-B149 (.1 or .2) installation code.

RECOMMENDED GAS PIPE DIAMETER				
Pipe Length	Schedule 40 Pipe Inside Diameter		Tubing, Type L Outside Diameter	
	Nat.	L.P.	Nat.	L.P.
0-10ft 0-3m	1/2" 12.7mm	3/8" 9.5mm	1/2" 12.7mm	3/8" 9.5mm
11-40ft 4-12m	1/2" 12.7mm	1/2" 12.7mm	5/8" 15.9mm	1/2" 12.7mm
41-100ft 13-30m	1/2" 12.7mm	1/2" 12.7mm	3/4" 19mm	1/2" 12.7mm
101-150ft 31-46m	3/4" 19mm	1/2" 12.7mm	7/8" 22.2mm	3/4" 19mm

NOTICE: Never use plastic pipe. Check to confirm whether your local codes allow copper tubing or galvanized.

NOTICE: Since some municipalities have additional local codes, it is always best to consult your local authority and installation code. The use of the following gas connectors is recommended:

- ANS Z21.24 Appliance Connectors of Corrugated Metal Tubing and Fittings.
- ANS Z21.45 Assembled Flexible Appliance Connectors of Other Than All-Metal Construction

The above connectors may be used if acceptable by the authority having jurisdiction. The state of Massachusetts requires that a flexible appliance connector cannot exceed three feet in length.

FLEXIBLE GAS LINE CONNECTION

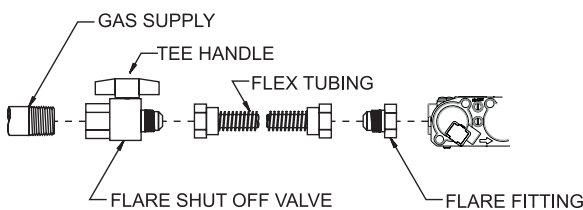

Figure 5

	Gas Supply Pressure (inches w.c.)		
	Minimum	Normal	Maximum
Natural Gas	4.5	7.0	14.0
LP (Propane)	10.8	11.0	14.0
	Manifold Pressure (inches w.c.)		
	Normal (HI)		
Natural Gas	3.5		
LP (Propane)	10.0		

Installing the Main Gas Cock

Each appliance should have its own manual gas cock. A manual main gas cock should be located in the vicinity of the unit. Where none exists, or where its size or location is not adequate, contact your local authorized installer for installation or relocation. Compounds used on threaded joints of gas piping shall be resistant to the action of liquefied petroleum gases. The gas lines must be checked for leaks by the installer. This should be done with a soap solution watching for bubbles on all exposed connections, and if unexposed, a pressure test should be made.

Never use an exposed flame to check for leaks. Appliance must be disconnected from piping at inlet of control valve and pipe capped or plugged for pressure test. Never pressure test with appliance connected; control valve will sustain damage!

When using copper or flex connector use only approved fittings. The appliance and its individual shut off valve must be disconnected from supply piping system during any pressure testing of that system at test pressures in excess of 1/2 psig (3.5kPa).

The appliance must be isolated from the gas supply piping system by closing its individual manual shut off valve during any pressure testing of the gas supply piping system at test pressures equal to or less than 1/2 psig (3.5kPa).

Attention! If one of the procedures results in pressures in excess of 1/2 psig (14" w.c.) (3.5 kPa) on the fireplace gas valve, it will result in a hazardous condition.

Checking Manifold Pressures

Both Propane and Natural gas valves have a built-in pressure regulator in the gas valve. Natural gas models will have a manifold pressure of approximately 3.5" w.c. (.871kPa) at the valve outlet with the inlet pressure to the valve from a minimum of 4.5" w.c. (1.120kPa) for the purpose of input adjustment to a maximum of 14.0" w.c. (3.484kPa). Propane gas models will have a manifold pressure approximately 10.0" w.c. (2.49kPa) at the valve outlet with the inlet pressure to the valve from a minimum of 10.8" w.c. (2.68kPa) for the purpose of input adjustment to a maximum of 14.0" w.c. (3.484kPa).

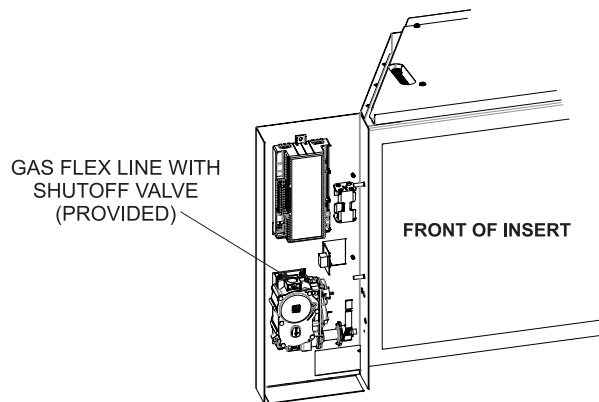

Figure 6

VENTING AND INSTALLATION

1. Before beginning, remove glass door and log package from unit. Also check to make sure there is no hidden damage to the unit. Take a minute and plan out the gas, venting and electrical route. It is best to start with the gas line first, followed by the chimney liner and electrical supply requirements.
2. Minimum fireplace opening requirements are shown in **Figure 2** of this installation manual. The firebrick (refractory), glass doors, screen rails, screen mesh and log grates can be removed from a fireplace in order to gain minimum gas insert opening requirements prior to installing the gas fireplace insert.
3. Although the insert does not require a hearth extension, only heat resistant materials such as stone, metal, tile, etc. should be used. Do not use vinyl, carpet, or wood based products within 16 inches of the insert face. Do not obstruct the lower louver (if included), or other vented openings on the insert. Note: The original fireplace cannot be returned to solid fuel use without returning the hearth extension to the specification required for a solid fuel fireplace.
4. The metal floor of the solid fuel firebox may be removed to facilitate the installation of the insert. **CLEARANCE TO COMBUSTIBLE MATERIAL UNDER THE INSERT IS 1/4 INCH. YOU MUST USE THE LEVELING LEGS TO RAISE THE INSERT A MINIMUM OF 1/4 INCH IF THE INSERT IS TO SIT ON COMBUSTIBLE MATERIAL.** The side walls and top structure of the firebox may not be altered with the exception of removable baffles and dampers. Smoke shields, shelves and baffles may be removed if attached with mechanical fasteners. The original fireplace cannot be returned to solid fuel in this condition.
5. The original specified clearances of a factory-built fireplace must be maintained, with the exception of the hearth. Clearances on a masonry fireplace must be maintained at 12 inches from the opening for combustible projections over 1-1/2 inch. Clearances for combustible projections under 1-1/2 inch must be maintained at 6 inches from the opening per NFPA211. Plan the surround size accordingly. A surround must be used with the insert. **UNDER NO CIRCUMSTANCE CAN COMBUSTIBLE MATERIAL BE PLACED BEHIND THE SURROUND!**
6. The insert surround is tested and approved with this gas insert and may cover existing air circulation vents or grilles on the solid fuel fireplace it is installed into. If the surround does not cover the entire ventilation grille surface, the exposed grille area should be left open.

NOTICE: Surround panel kits have been tested and approved to cover existing air circulation vents or grilles.

NOTICE: Cutting of sheet metal parts of a fireplace in order to install the fireplace insert is prohibited.

WARNING

Only the surround as supplied may be used to cover integral grilles on the solid fuel-burning fireplace. No other components such as surrounds, sheet metal plates, etc. may be used to seal off vents.

7. To assure top performance, safety and efficiency, inserts must be installed with an approved flue liner as per CAN/CGA B-149 or National Fuel Code ANSI Z223 and these instructions.

NOTICE: The following statement is also provided on a separate label plate in the instruction packet. Prior to installation of the fireplace insert, the installer must mechanically secure this warning plate to the inside of the fireplace for future reference as required.

WARNING

The solid fuel fireplace has been converted for use with gas only and cannot be used for burning wood or solid fuels unless all original parts have been replaced and the fireplace has been reapproved by the authority having jurisdiction.

8. The solid fuel fireplaces' flue damper must be fully locked in the open position or removed for installation of the gas fireplace insert.
9. The fireplace and fireplace chimney must be cleaned and in good working order and constructed of noncombustible materials.
10. Make sure that all chimney cleanouts fit properly so air cannot leak into the chimney.
11. Install the insert without the surround panels attached and make all gas, venting, and electrical connections.
12. To complete the installation, install surround panel assembly. Please refer to instructions included with the surround panel kit.

CAUTION

Ensure there are no obstructions to side air passages of decorative trim once installed on insert.

INSTALLING THE VENT SYSTEM

Vent System Installation Precautions

Before starting installation of vent kits, the installer should read these instructions and the Vent Kit Instructions to ensure that a proper vent installation is completed. Consult your local Building Codes before beginning the Installation.

WARNING

THIS GAS INSERT AND VENT ASSEMBLY MUST BE VENTED DIRECTLY TO THE OUTSIDE AND MUST NEVER BE ATTACHED TO A CHIMNEY SERVING A SEPARATE SOLID FUEL BURNING APPLIANCE. EACH GAS APPLIANCE MUST USE A SEPARATE VENT SYSTEM. COMMON VENT SYSTEMS ARE PROHIBITED.

VENTING AND INSTALLATION

Vent System Approvals

Figure 9 shows the vent termination caps and systems approved for use with these models. Approved vent system terminations are labeled for identification. 3-inch diameter listed flexible aluminum or stainless steel gas vent is used for both the incoming combustion air and exhaust vent pipes. **NO OTHER VENTING SYSTEMS OR COMPONENTS MAY BE USED.** Detailed installation instructions are included with each vent termination kit and should be used in conjunction with this manual. See page 5 for approved venting kits.

Horizontal Venting

The vent system on this model **CANNOT** be terminated horizontally.

Vertical Venting

The inlet and exhaust vent pipes **MUST** be connected to the proper collars on the unit **AND** to the termination cap or the unit will not operate. See Figure 7.

⚠ WARNING

MAJOR U.S. BUILDING CODES SPECIFY MINIMUM CHIMNEY AND/OR VENT HEIGHT ABOVE THE ROOF TOP. THESE MINIMUM HEIGHTS ARE NECESSARY IN THE INTEREST OF SAFETY. SEE FIGURES 9 TO 11 FOR MINIMUM HEIGHTS, PROVIDED THE TERMINATION CAP IS AT LEAST 2-FEET FROM A VERTICAL WALL AND 2-FEET BELOW A HORIZONTAL OVERHANG.

NOTICE: This also pertains to vertical vent systems installed on the outside of the building.

⚠ WARNING

THE EXHAUST PIPE MUST ONLY BE CONNECTED TO THE EXHAUST STARTING COLLAR OF THE UNIT AND TO THE EXHAUST COLLAR OF THE TERMINATION CAP.

THE INLET AIR PIPE MUST ONLY BE CONNECTED TO THE INLET AIR STARTING COLLAR OF THE UNIT AND TO THE INLET AIR COLLAR OF THE TERMINATION CAP. BOTH THE INLET VENT AND THE FLUE VENT MUST BE CONNECTED FROM THE INSERT TO THE VENT TERMINATION CAP.

NOTICE: The minimum vertical vent rise is 10 feet and the maximum vertical vent rise is 40 feet. These dimensions are measured from the starting collars of the unit to the end of the last section of vent pipe. See Figure 9.

NOTICE: The damper of the masonry chimney may need to be removed to allow installation of the flexible-vent pipe.

When installing into a zero clearance, factory built wood-burning fireplace, the use of the DVKI Round Vertical Termination Kit should allow you to mount the vent adaptor and cap to the exposed round chimney pipe easily.

Connecting the Vent Pipe

⚠ CAUTION

Sharp edges. Always use gloves when installing.

Install the 3-inch flexible vent pipes down through the chimney.

Attach the pipe-to-cap adaptor to the termination cap and the top of the flexible vent pipe, then install the cap to the top of the chimney.

Remove the vent slide plate assembly from the top of the insert. See Figure 8. Trim off excess venting then attach and secure

the bottom ends of the flex pipes to the starting collars with the adjustable band clamps provided. Slide the gas insert into place, and position any excess flex vent pipe back up into the chimney. Begin installation of the insert into the fireplace opening. Align the vent slide plate assembly with the guides located on top of the insert. Work the insert inch by inch into the fireplace cavity as you pull forward on the vent slide plate assembly. Do not use excessive force on the vent slide plate. Once the vent slide plate is close to seating, install the bolt (provided in the installation envelope) through the center hole of the insert top flange, and into the vent slide plate nut. Using a wrench, tighten the bolt until the vent slide plate is seated forward completely.

Positioning, Leveling, and Securing Insert

1. Place the insert into position.
2. Level the insert from side to side and front to back.
3. If necessary, use the leveling bolts included in the instruction pack. Screw the legs into the nuts installed in the bottom of the insert. Turn legs in until insert is level.

NOTICE: If desired, it is acceptable to attach metal strapping or brackets (not provided) from the fireplace cavity to the insert outer jacket to secure the Fireplace Insert to the fireplace hearth or opening.

⚠ CAUTION

TO AVOID DOWNDRAFTS AND/OR COLD AIR PROBLEMS, IT IS RECOMMENDED TO SEAL OFF THE AREA BETWEEN THE TERMINATION CAP AND THE TOP OF THE SOLID-FUEL CHIMNEY OPENING INTO WHICH THE VENT CAP HAS BEEN INSTALLED.

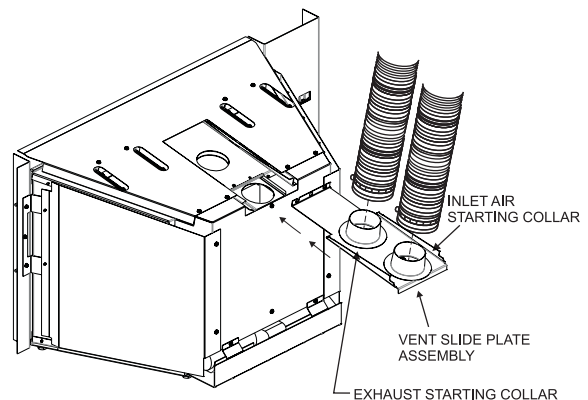
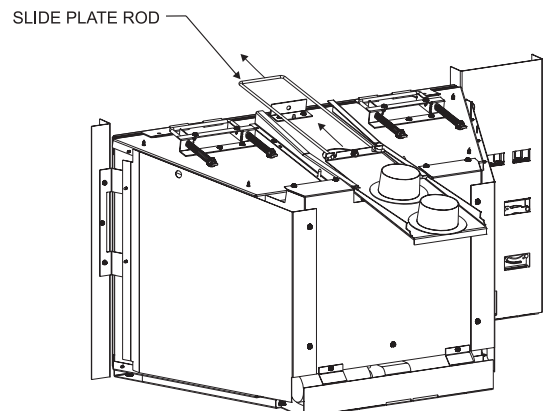

Figure 7



NOTE: TOP OF FIREPLACE HAS BEEN REMOVED FOR CLARITY

Figure 8

VENTING AND INSTALLATION

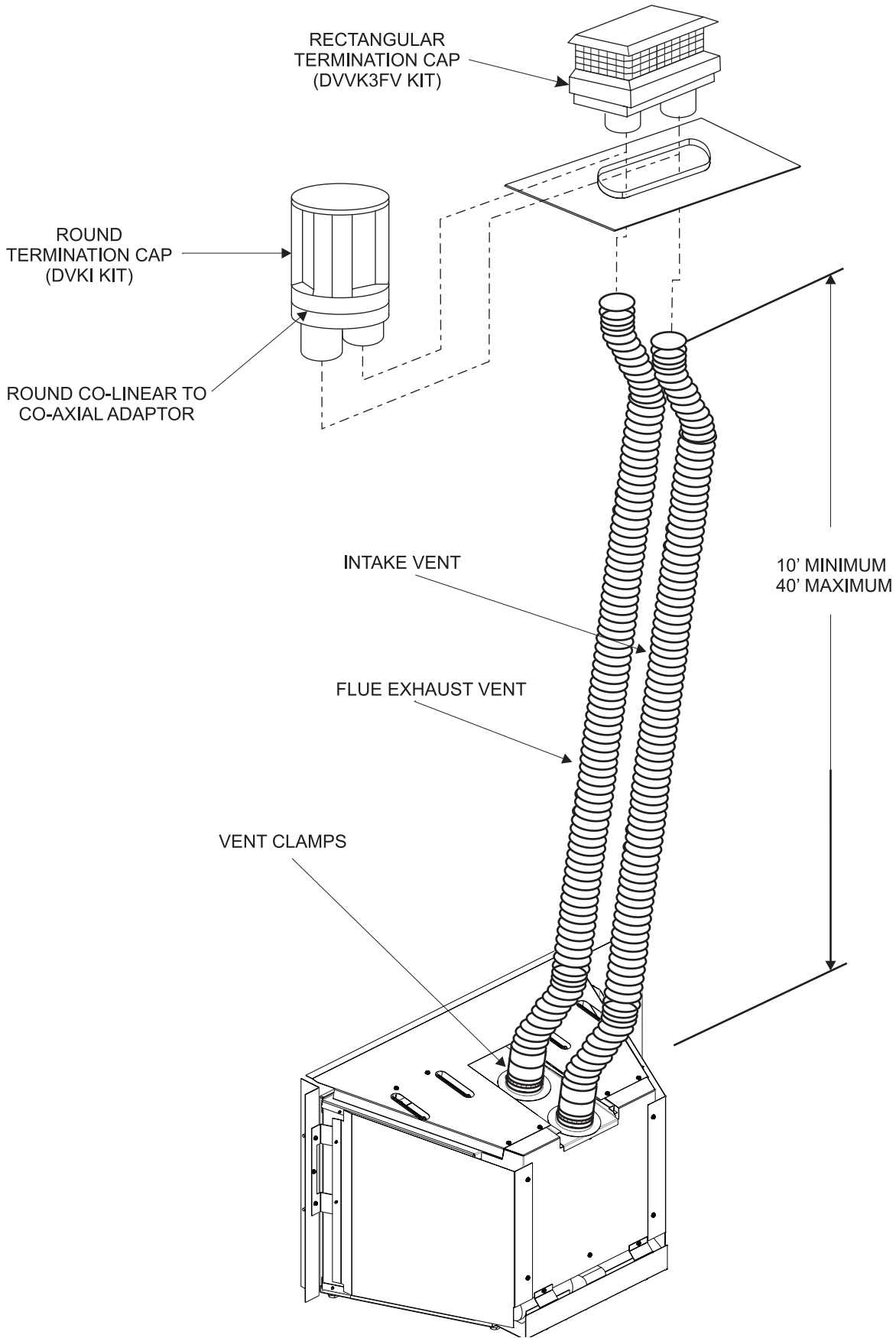

Figure 9

VERTICAL TERMINATION

Determining Minimum Vent Height Above the Roof.

⚠ WARNING

Major U.S. building codes specify minimum chimney and/or vent height above the roof top. These minimum heights are necessary in the interest of safety. These specifications are summarized in Figure 10.

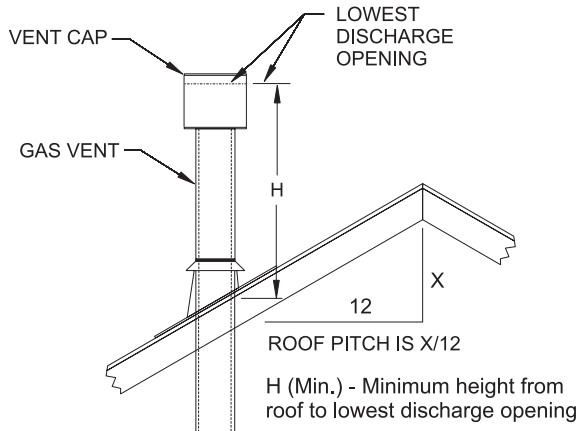

ROOF PITCH	H (Min.)
Flat to 6/12	12" (305 mm)
6/12 to 7/12	15" (381 mm)
Over 7/12 to 8/12	18" (457 mm)
Over 8/12 to 16/12	24" (610 mm)
Over 16/12 to 21/12	36" (914 mm)

Figure 10

NOTICE: For steep roof pitches, the vent height must be increased. In high wind conditions, nearby trees, adjoining roof lines, steep pitched roofs, and other similar factors can result in poor draft, or down-drafting. In these cases, increasing the vent height may solve this problem.

When terminating the vent cap near an exterior wall or overhang, maintain minimum clearances as shown in **Figure 11**.

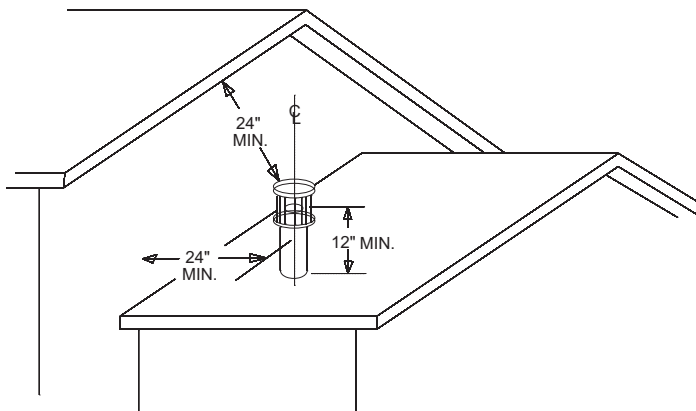

Figure 11

Vertical Through the Roof Applications

The Gas Fireplace Insert has been approved for:

- Vertical installations up to 40 feet in height (top of insert to cap).
- Ensure that existing vent run has no more than two sets of 45 degree elbow offsets within the vertical installation. From 0 to a maximum of 8 ft. of vent pipe can be used between elbows.
- Ensure that the existing vent run is support as follows: Wall straps must be used to support offset pipe every 4'.

This application will require that you first determine the roof pitch and use the appropriate venting components.

General Maintenance

Conduct an inspection of the venting system semi-annually. Recommended areas to inspect are as follows:

- Check areas of the venting system which are exposed to the elements for corrosion. These will appear as rust spots or streaks and, in extreme cases, holes. These components should immediately be replaced.
- Remove the cap and shine a flashlight down the vent. Remove any bird nests or other foreign material.
- Check for evidence of excessive condensate, such as water droplets forming in the flex venting and subsequently dripping out at joints or seams. Condensate can cause corrosion of caps, pipe and fittings. It may be caused by having excessive lateral runs, or having exterior portions of the system exposed to cold weather.
- Inspect joints to verify that no pipe sections or fittings have been disturbed and, consequently, loosened. Also, check mechanical supports, such as wall straps or metal plumbers' tape for rigidity.

GLASS & SCREEN ASSEMBLY REMOVAL

1. Remove the screw securing the screen assembly to the insert. Lift the assembly up and pull out to remove it from the insert. See Figure 12.

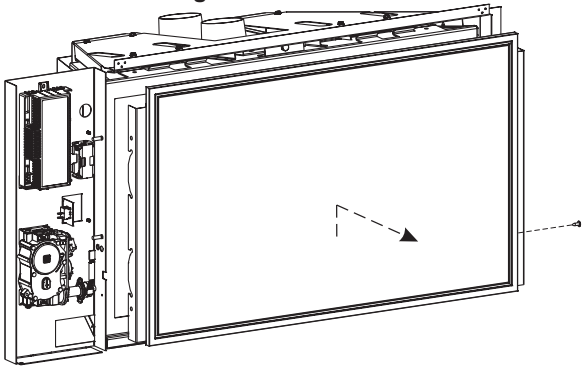

Figure 12

2. Secure the glass assembly in place with one hand.
3. Insert the Latch Tool into the firebox at the top and hook it onto the right glass clip.
4. Using steady force, pull the latch out and up until it disengages from the glass assembly.

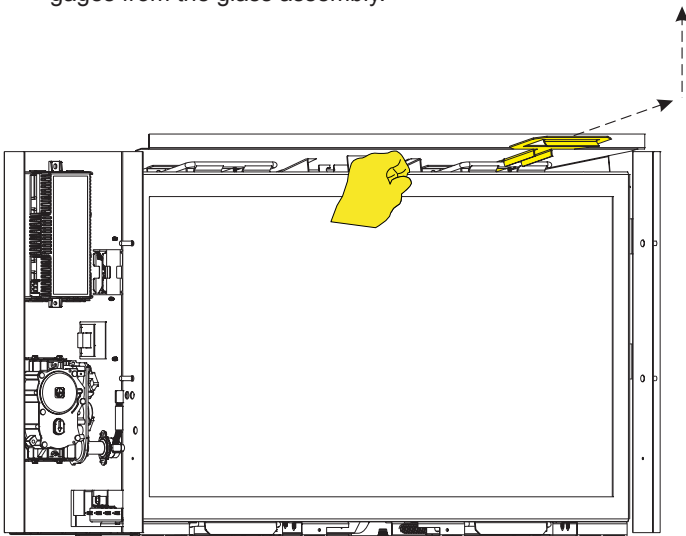

Figure 13

5. Repeat step 4 for the left glass clip.

CAUTION

Top glass clips are tightly sprung. If the Latch tool slips off of the clip while pulling, injury may occur. Ensure that the latch tool is completely hooked around the glass clips before trying to disengage the glass clips from the glass assembly.

NOTICE: Latch tool must be stored near unit.

6. Angle the glass towards you from the top and firmly pull out.

CAUTION

Bottom glass clips do not require use of the latch tool to disengage them from the glass assembly. However, they are tightly sprung and some force is needed to disengage them from the glass assembly.

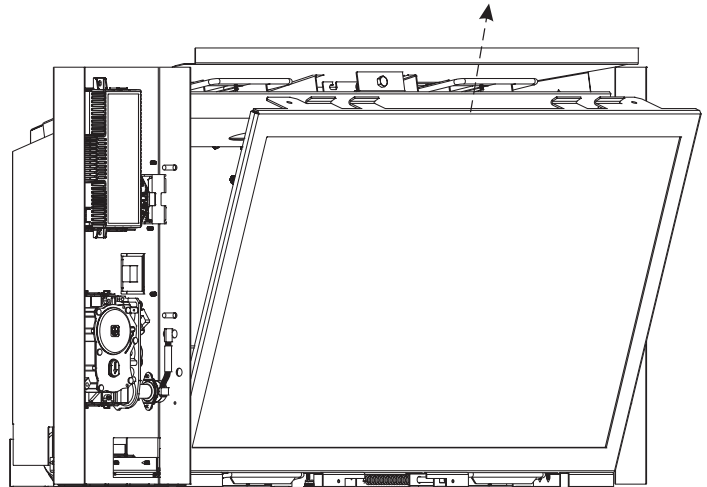

Figure 14

GLASS & SCREEN ASSEMBLY PLACEMENT

1. Place the bottom of the glass assembly into the firebox and angle the top in.

CAUTION

Ensure the bottom glass clips engage to the glass assembly.

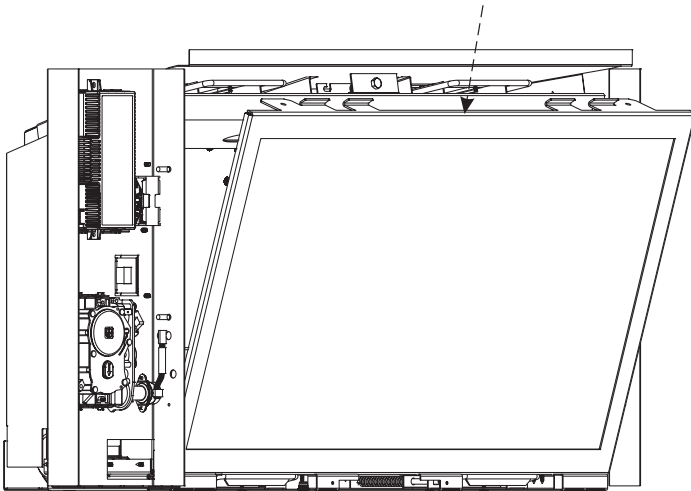

Figure 15

2. Secure the glass assembly in place with one hand.
3. Insert the Latch Tool into the firebox at the top and hook it onto the right glass clip.
4. Using steady force, pull the latch out and up until it engages to the glass assembly.

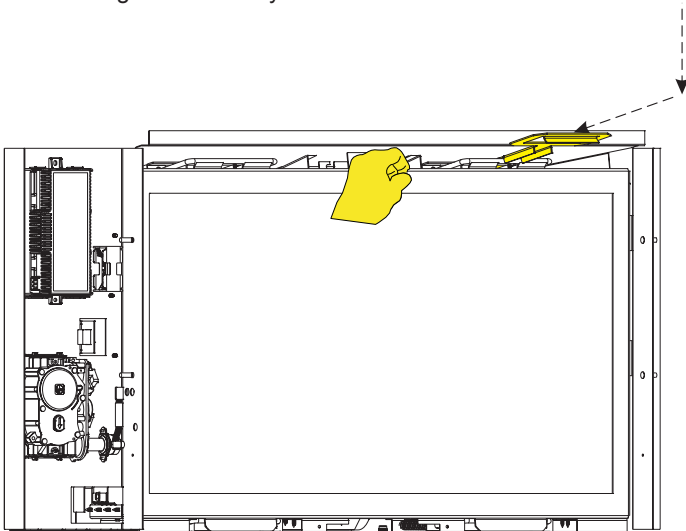

Figure 16

5. Repeat step 4 through 5 for the left glass clip.

CAUTION

Top glass clips are tightly sprung. If the Latch tool slips off of the clip while pulling, injury may occur. Ensure that the latch tool is completely hooked around the glass clips before trying to engage the glass clips to the glass assembly.

6. Place the screen on the four pegs (two each side) on the firebox. Secure with screw as shown in Figure 17.

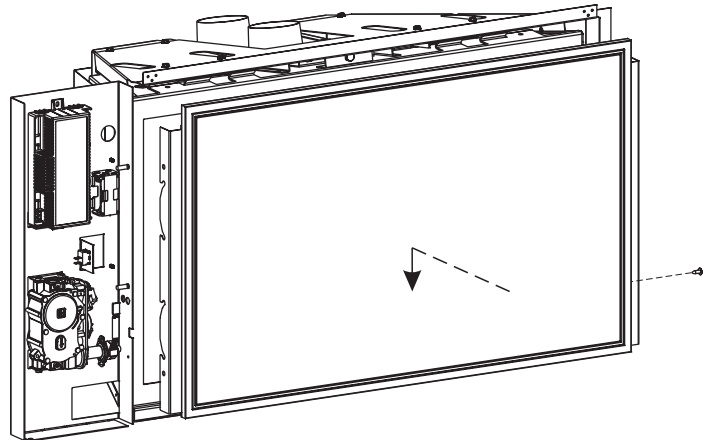









Figure 17

LOG IDENTIFICATION

Note: Install firebox liners before installing log set. Refer to the installation instructions that came with your liners for more information.

LOG IDENTIFICATION CHART - TOP VIEW

Log ID	Picture
(A) Rear Log DXT30 Part No. 37885 DXT35 Part No. 37892	
(B) Left Log DXT30 Part No. 31212 DXT35 Part No. 37891	
(C) Right Log DXT30 Part No. 37886 DXT35 Part No. 37893	
(D) Log Chunk DXT30 Part No. 32008 DXT35 Part No. 32009	
(E) Front Left Log DXT30 Part No. 31215 DXT35 Part No. 31222	
(F) Front Right Log DXT30 Part No. 31217 DXT35 Part No. 31224	
(G) Center Log DXT30 Part No. 37888 DXT35 Part No. 37895	

Burner Pin Locations

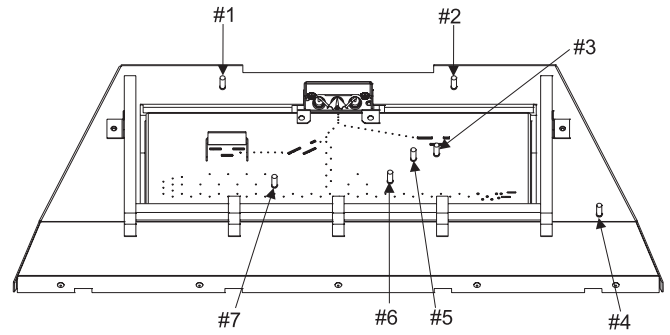
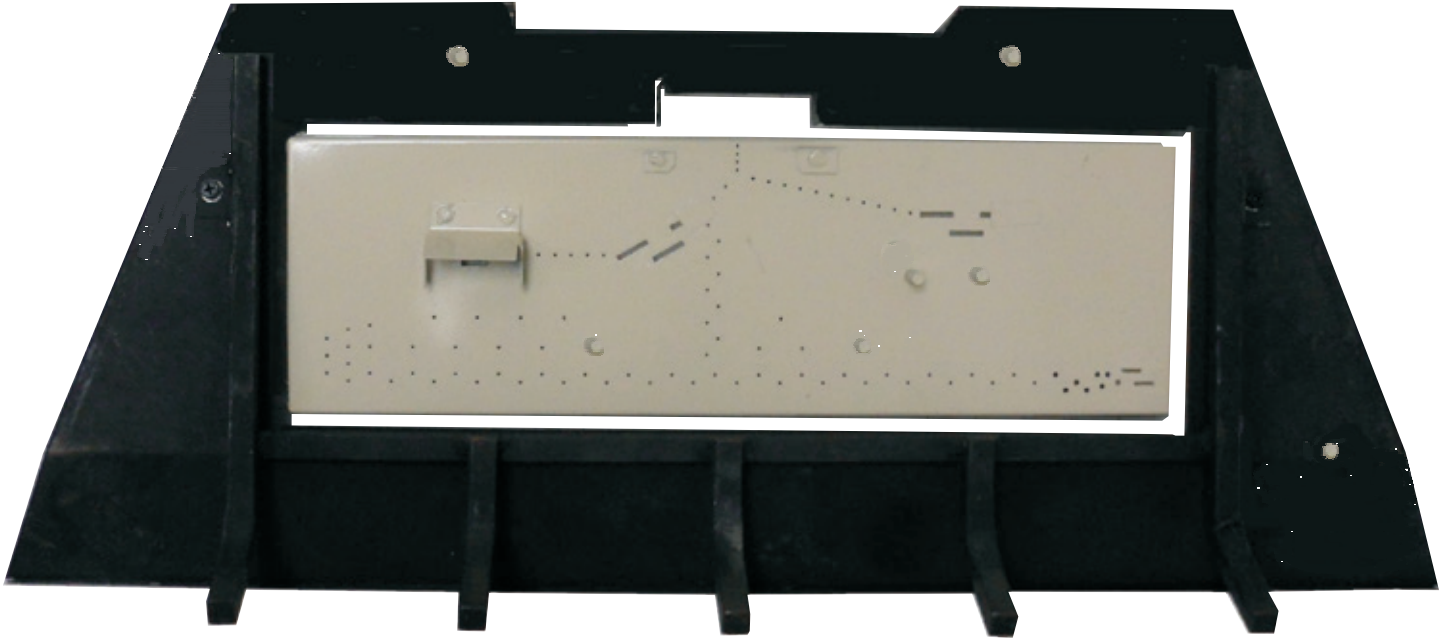

Figure 18

LOG PLACEMENT

One bag of embers is included with the original purchase of the appliance. Use only half of the bag (approximately 0.4 oz) for ember placement and save the rest for use after maintenance.



Notice: Burner Pins #1,2, and 4 shown gray for clarity.

EMBER PLACEMENT - EMPTY BURNER (DXT30 Shown)



Notice: Cover all ports except slots.
Notice: DXT35 has a different port pattern.

EMBER PLACEMENT - BURNER WITH LOGS (DXT30 Shown)

LOG PLACEMENT

1. Place Rear Log (A) onto burner pins #1 and #2. See Figure 18 for burner pin identification.



TOP VIEW (DXT30 Shown)



FRONT VIEW (DXT30 Shown)

LOG PLACEMENT

2. Place Left Log (B) onto the two left pins on (A) log and angled down to sit outside the grate.
NOTICE: Log should not touch grate tang.



TOP VIEW (DXT30 Shown)

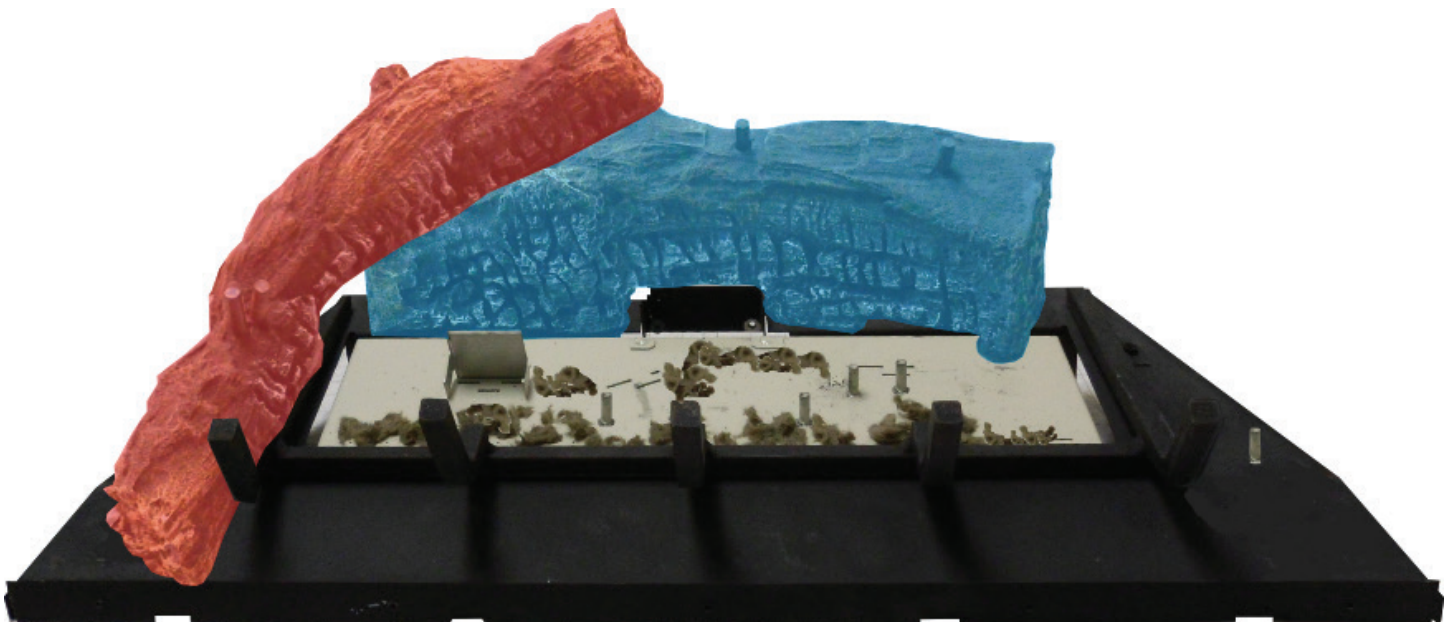

FRONT VIEW (DXT30 Shown)

LOG PLACEMENT

3. Place Right Log (C) onto the two right pins on (A) log and angled down to sit outside the grate and onto burner pin #4. See Figure 18 for burner pin identification.

NOTICE: Log should not touch grate tang.



TOP VIEW (DXT30 Shown)

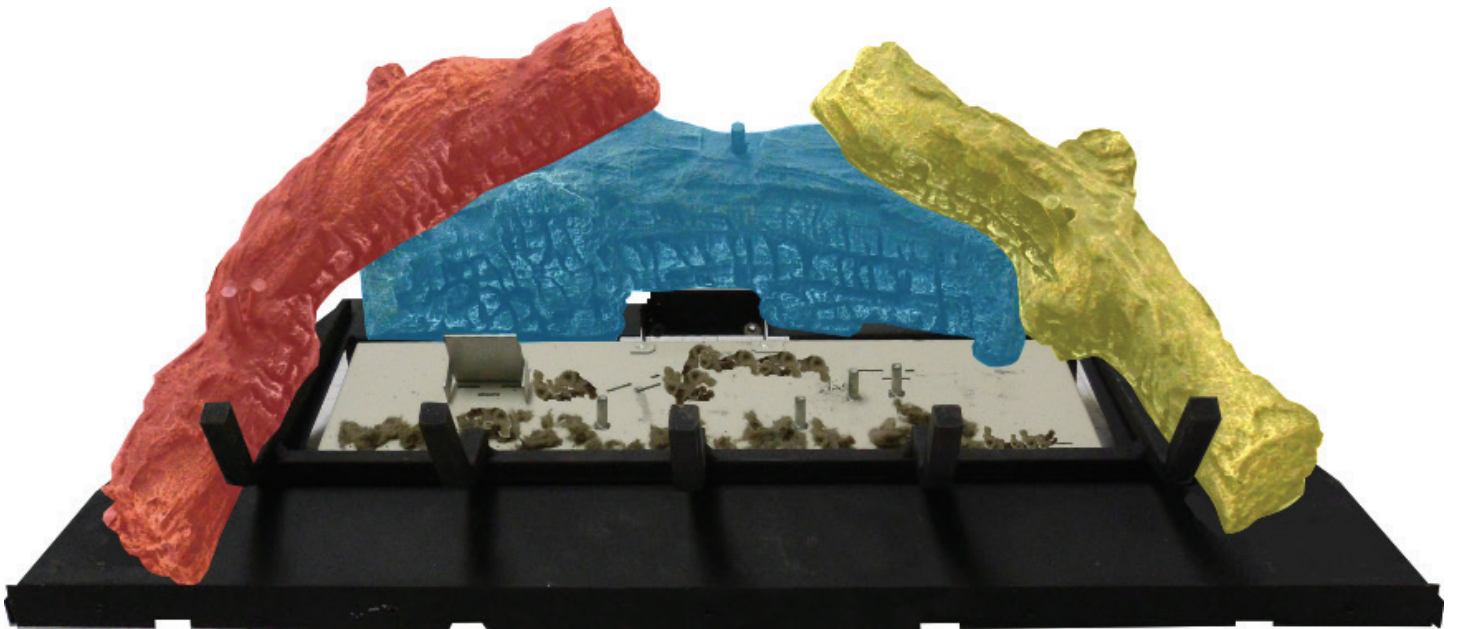

FRONT VIEW (DXT30 Shown)

LOG PLACEMENT

4. Place Log Chunk (D) onto burner pins #3 and #5. See Figure 18 for burner pin identification.



TOP VIEW (DXT30 Shown)

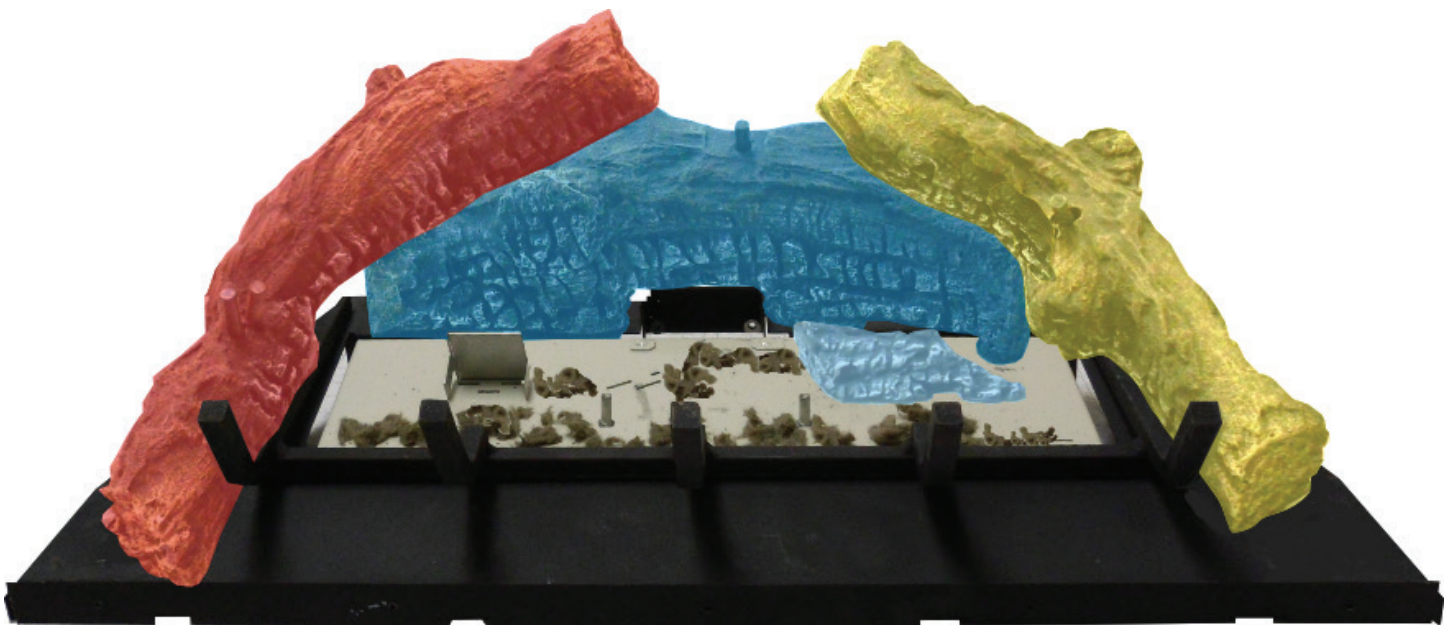

FRONT VIEW (DXT30 Shown)

LOG PLACEMENT

5. Place Right Center Log (F) onto the two pins on (C) log and burner pin #6. See Figure 18 for burner pin identification.



TOP VIEW (DXT30 Shown)



FRONT VIEW (DXT30 Shown)

LOG PLACEMENT

- Place Left Center Log (E) onto the two pins on (B) log and burner pin #7. See Figure 18 for burner pin identification.



TOP VIEW (DXT30 Shown)

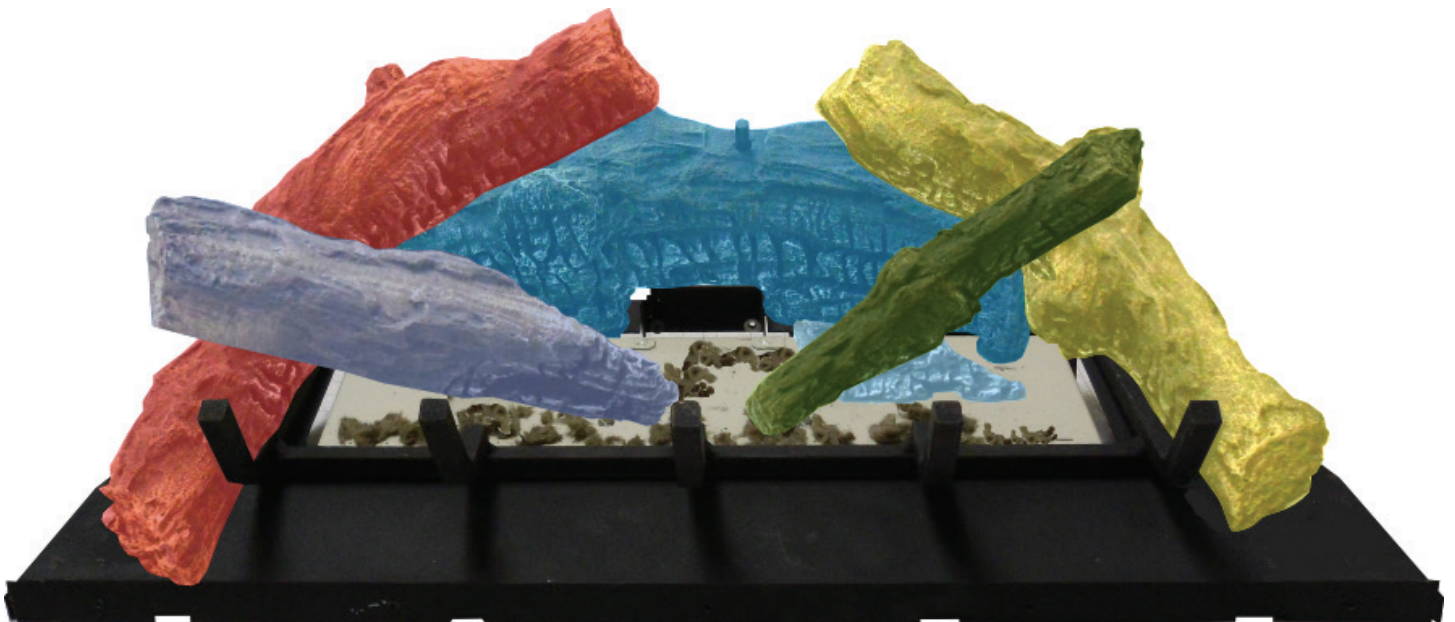

FRONT VIEW (DXT30 Shown)

LOG PLACEMENT

7. Place Front Log (G) onto the center pin on (A) log and against the back of the center grate tang.



TOP VIEW (DXT30 Shown)

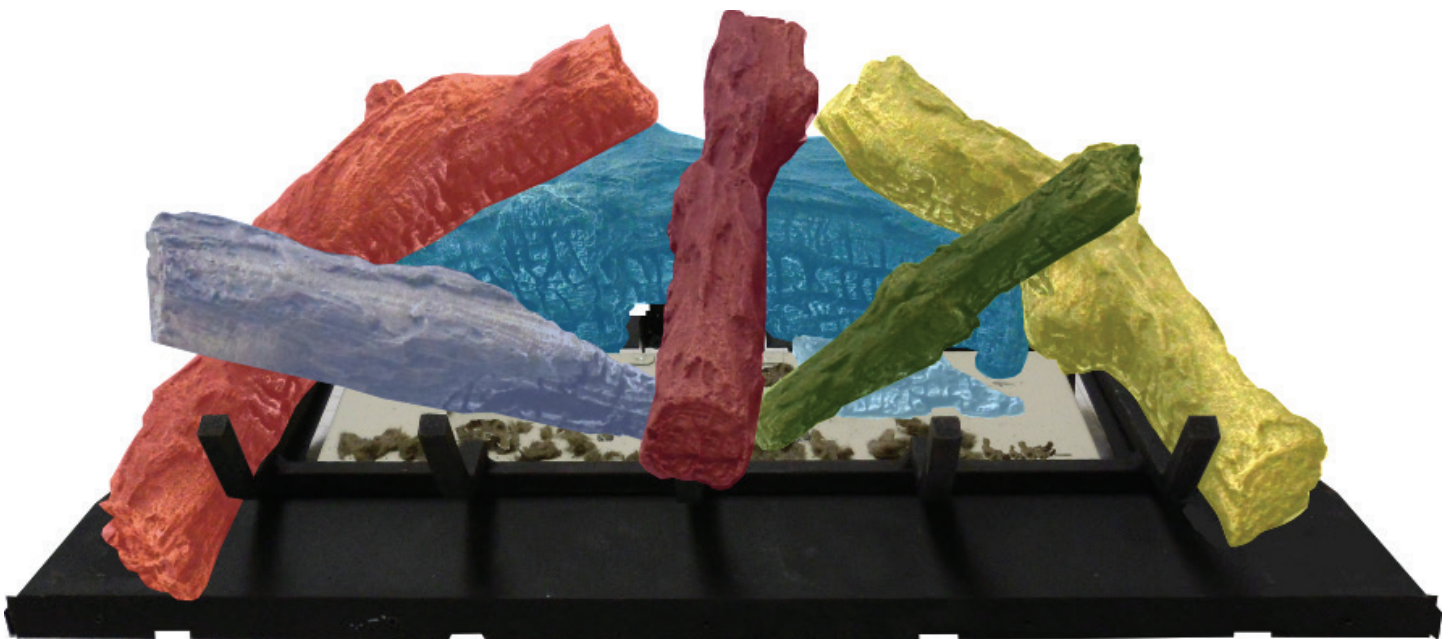

FRONT VIEW (DXT30 Shown)



LIGHTING INSTRUCTIONS

FOR YOUR SAFETY READ BEFORE LIGHTING

⚠ WARNING: If you do not follow these instructions exactly, a fire or explosion may result causing property damage, personal injury or loss of life.

- A. This appliance is equipped with an ignition device which automatically lights the pilot. Do not try to light the pilot by hand, use the remote control. Before lighting the pilot, ensure that the master switch is on. When lighting the pilot, follow these instructions exactly.
- B. Before lighting smell all around the appliance area for gas. Be sure to smell next to the floor because some gas is heavier than air and will settle on the floor.
- What To Do If You Smell Gas
- Do not try to light any appliance.
 - Do not touch any electrical switch;
 - Do not use any phone in your building.
 - Immediately call your gas supplier from a neighbor's phone.
- Follow the gas supplier's instructions.
- If you cannot reach your gas supplier, call the fire department.
- C. Use only the remote control to operate the gas valve. Never use tools. If valve does not operate, don't try to repair it, call a qualified service technician. Force or attempted repair may result in a fire or explosion.
- D. Do not use this appliance if any part has been under water. Immediately call a qualified service technician to inspect the appliance and to replace any part of the control system and any gas control which has been under water.

LIGHTING INSTRUCTIONS

1. STOP! Read the safety information above.
2. Turn OFF electric power to the appliance.
3. Remove front surround assemblies.
4. Turn gas cock counterclockwise  to "ON" position.
5. Wait ten minutes to clear out any gas. Then smell for gas, including near the floor. If you smell gas, STOP! Follow "B" in the safety information above. If you do not smell gas, go to the next step.
6. Turn ON electric power to the appliance.
7. Find pilot. The pilot is behind the burner.
8. Do not try to light the pilot by hand. Turn main flame to ON using your remote. If the pilot does not light within 60 seconds, stop and go to step 5.
9. If the burner or pilot does not operate properly after several tries, turn the gas cock clockwise  to "OFF" and call your service technician or gas supplier.
10. Replace the front surround assemblies.
11. Operation of the gas valve is controlled by a hand held remote control. Refer to remote instructions for detailed operation information.

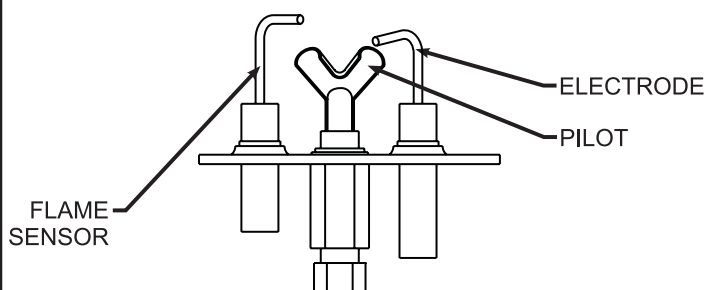

GAS COCK

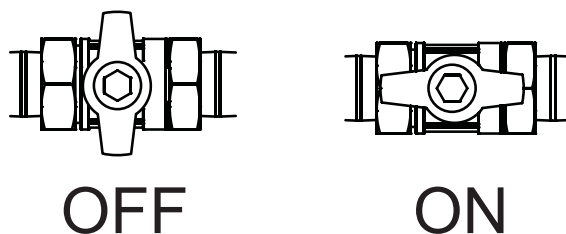

TO TURN OFF GAS TO FIREPLACE

1. Turn off all electric power to the appliance if service is to be performed.
2. Gain access to the control compartment by removing surround assemblies.
3. Locate On/Off gas cock and turn clockwise  to "OFF". Do not force.
4. Replace surround assemblies removed in step 2.

IPI SYSTEM WIRING DIAGRAM

DX(L,T)IN

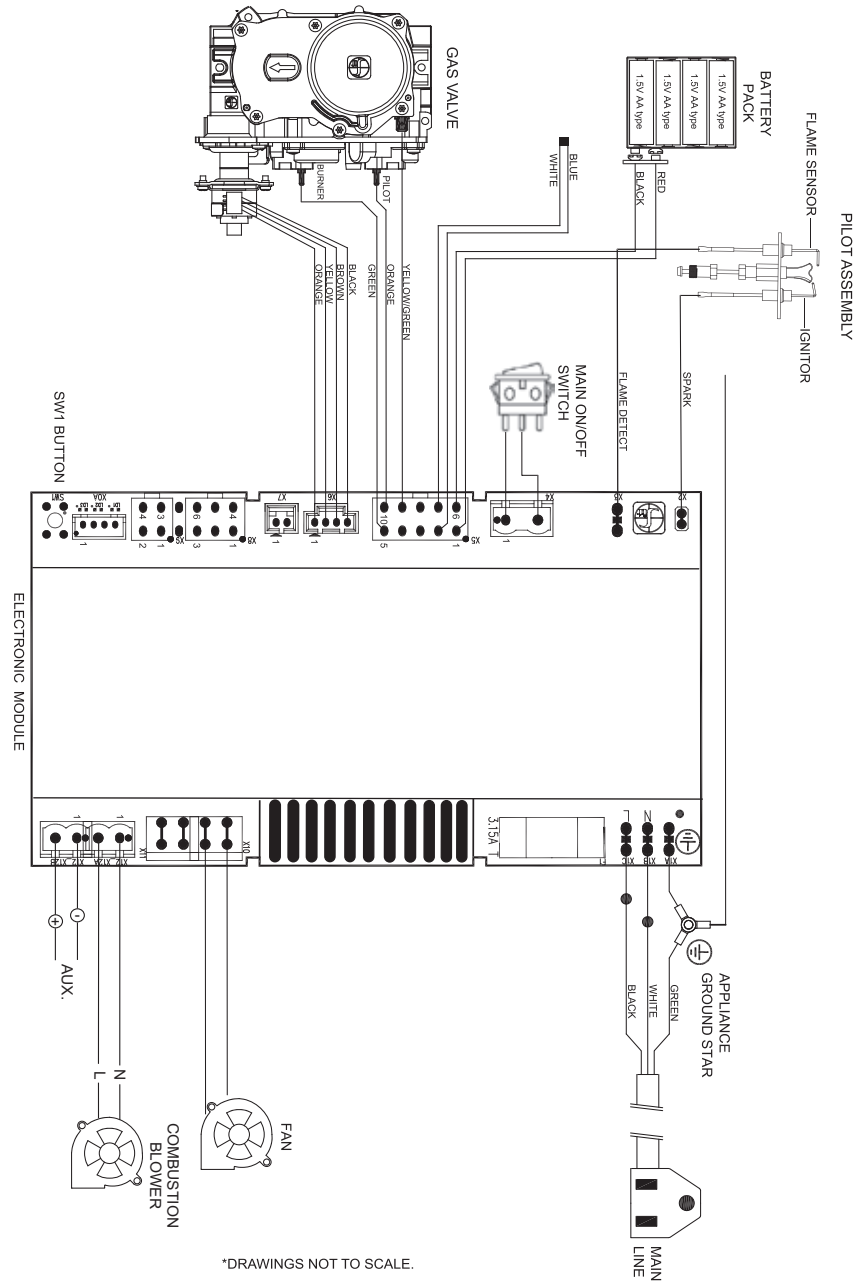

*DRAWINGS NOT TO SCALE.

If any of the original wire as supplied with this unit must be replaced, it must be replaced with equivalent gauge and temperature rated wire.

This appliance is only for use with the type of gas indicated on the rating plate and may be installed in an aftermarket, permanently located, manufactured (mobile) home where not prohibited by local codes. This appliance is not convertible for use with other gases, unless a certified kit is used.

⚠ CAUTION

Do not operate the appliance with glass panel removed, cracked or broken. Replacement of the panel should be done by a licensed or qualified service person.

⚠ WARNING

Improper installation, adjustment, alteration, service or maintenance can cause property damage, personal injury or loss of life. Installation and service must be performed by a qualified installer, service agency or the gas supplier.

REMOTE CONTROL OPERATION INSTRUCTIONS

NOTICE: ON/OFF rocker switch must be ON for the remote to operate.

Features:

- Main Burner ON/OFF
- Main Burner flame modulation (6 levels)
- Choice of standing or intermittent pilot
- Thermostat or Smart thermostat functions
- On/Off relay*
- Comfort Fan speed modulation (6 levels)

*Not available on DXT(30,35)IN models.

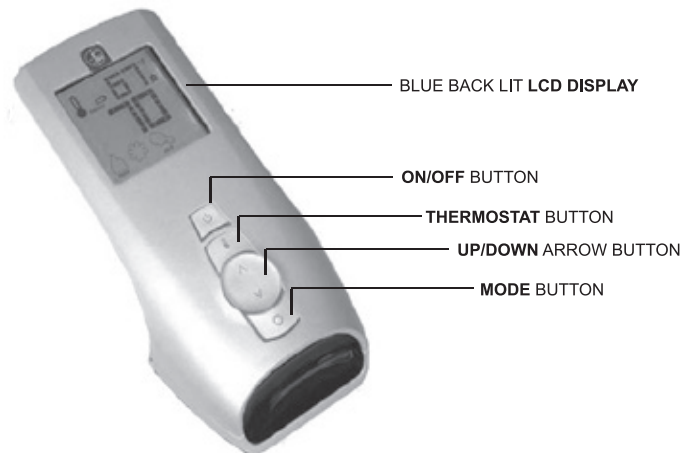

Figure 19a

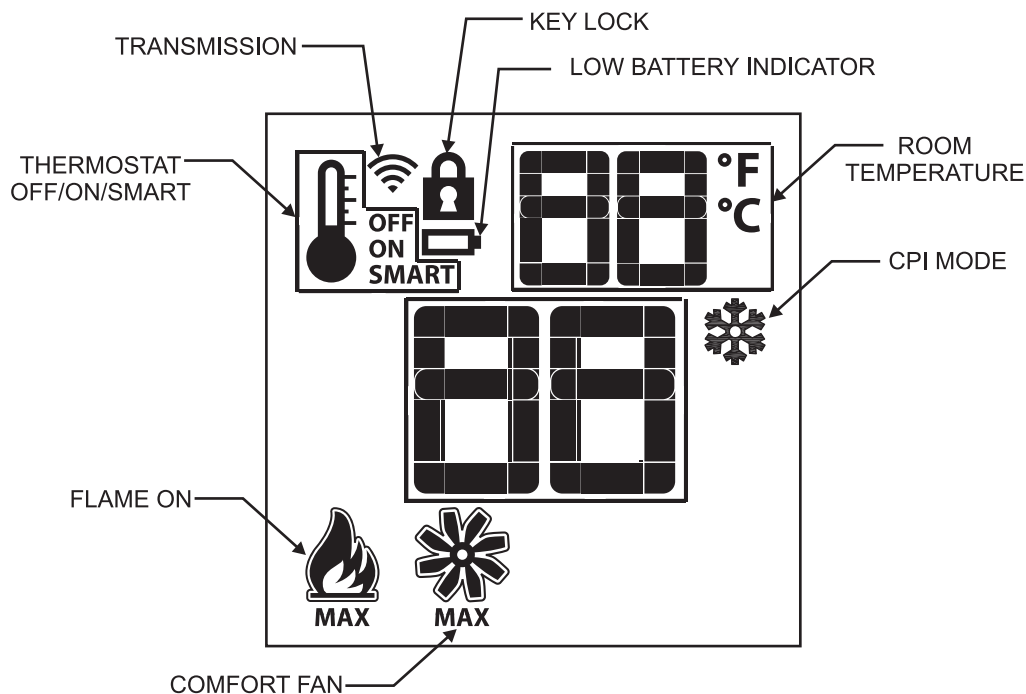

Figure 19b

Remote Control Information

Supply Voltage: 4.5 V (three 1.5 V AAA batteries)
 Ambient Temperature Ratings: 0 - 50°C (32 - 122°F)
 Radio Frequency: 315 MHz

NOTICE: THE TRANSMITTER AND RECEIVER ARE RADIO FREQUENCY DEVICES. PLACING THE RECEIVER IN OR NEAR METAL SEVERELY REDUCES THE SIGNAL RANGE.

NOTICE: TURN "OFF" THE MAIN GAS SUPPLY OF THE APPLIANCE DURING INSTALLATION OR MAINTENANCE OF THE RECEIVER DEVICE.

NOTICE: FOR INSTALLATION/MAINTENANCE, SWITCH OFF THE INSERT BY REMOVING MAIN POWER SUPPLY AND BATTERIES IF INSTALLED.

WARNING

- **FIRE HAZARD.** Can cause severe injury or death.
- The Transmitter causes ignition of the appliance. The appliance can turn on suddenly.
- Keep away from the appliance burner when operating the remote system.

REMOTE CONTROL OPERATION INSTRUCTIONS

Initializing the System for the First Time

1. Install the three AAA type batteries in the Transmitter battery bay located on the base of the Transmitter (back side). **See Figure 20.**
2. Power the receiver
3. With the ON/OFF rocker switch turned ON, press red button on the module.
4. The Receiver will “beep” three times to indicate that it is ready to synchronize with a Transmitter.
5. With the batteries already installed in the Transmitter, push the “ON” button. The Receiver will “beep” to indicate the Transmitter’s command is accepted and set to the particular code of that Transmitter.
6. The system is now initialized.



Figure 20

Temperature Indication Display

With the system in the “OFF” position, press the THERMOSTAT key and the MODE key at the same time.

Look at the LCD screen on the Transmitter to verify that a °C or °F is visible to the right of the Room Temperature display. **See Figures 21a and 21b.**

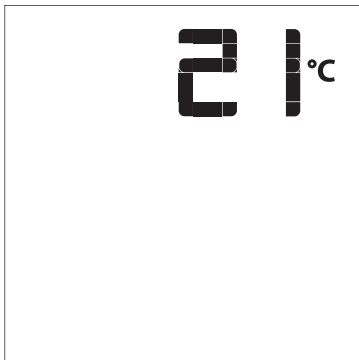

Figure 21a - Degrees Celsius



Figure 21b - Degrees Fahrenheit

Turn the Appliance ON and OFF

1. With the system OFF, press the ON/OFF key on the Transmitter. The Transmitter LCD display will show some other active Icons on the screen. At the same time the Receiver will activate the appliance.
2. A “beep” from the Receiver will confirm reception of the command.
3. TURN OFF THE APPLIANCE
4. With the system ON , press the ON/OFF Key on the Transmitter. The Transmitter LCD display will show the room temperature. **See Figure 22.** At the same time the Receiver will turn off the appliance.
5. A “beep” from the Receiver confirms reception of the command.

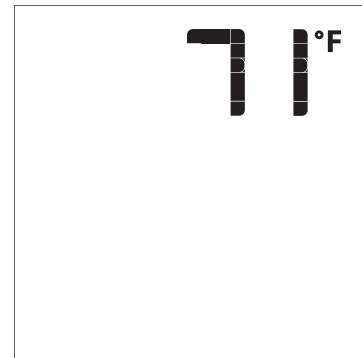

Figure 22

REMOTE CONTROL OPERATION INSTRUCTIONS

Remote Flame Control

The Proflame has six flame levels.

With the system ON and the flame level at the maximum in the appliance, pressing the DOWN ARROW key once will reduce the flame height by one step until the flame is turned OFF.

The UP ARROW key will increase the flame height each time it is pressed.

If the UP ARROW key is pressed while the system is ON but the flame is OFF, the flame will come ON in the high position.

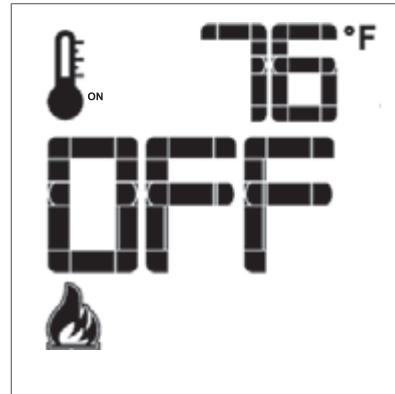

Figure 23 - Flame OFF

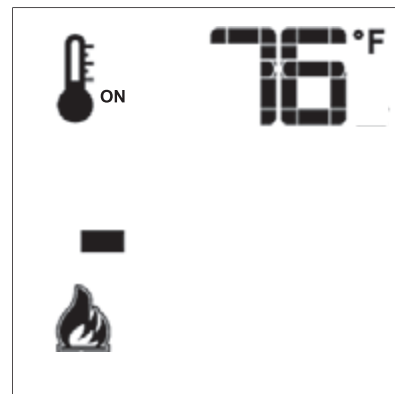

Figure 24 - Flame Level 1

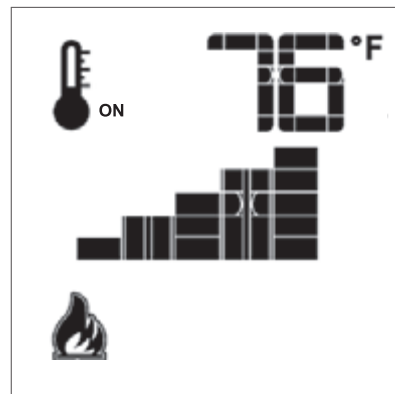

Figure 25 - Flame Level 5

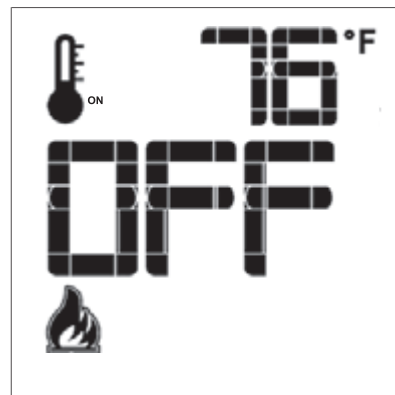

Figure 26 - Flame Level Maximum

REMOTE CONTROL OPERATION INSTRUCTIONS

Thermostat Transmitter Operation

The Remote Control can operate as a room thermostat. The thermostat can be set to a desired temperature to control the comfort level in a room.

To activate the function, press the THERMOSTAT key. **See Figure 19a.** The LCD display on the Transmitter will change to show that the room thermostat is "ON" and the set temperature is now displayed. **See Figure 27.**

To adjust the set temperature, press the UP or DOWN ARROW keys until the desired set temperature is displayed on the LCD screen of the Transmitter.

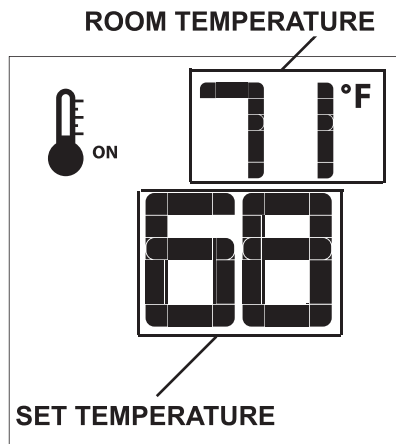

Figure 27

SMART Thermostat Operation

The Smart Thermostat function adjusts the flame height in accordance with the difference between the set point temperature and the actual room temperatures.

As the room temperature gets closer to the set point the Smart Function will modulate the flame down.

To activate this function, press the THERMOSTAT key until the word "SMART" appears to the right of the temperature bulb graphic.

To adjust the set temperature, press the UP or DOWN ARROW keys until the desired set temperature is displayed on the LCD screen of the Transmitter.

NOTICE: When Smart Thermostat is activated, the manual flame height adjustment is disabled.

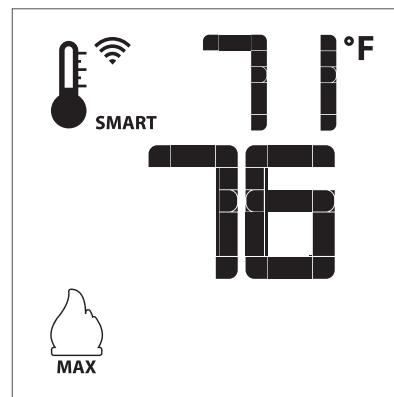

Figure 28 - SMART Function Icon

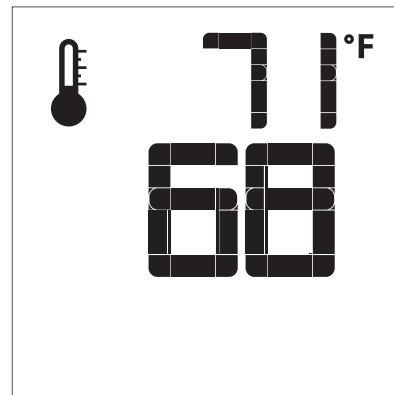

Figure 29

REMOTE CONTROL OPERATION INSTRUCTIONS

Fan Speed Control

The speed of the fan can be controlled by the Proflame system. The fan speed can be adjusted through six speeds.

To activate this function, use the MODE key (Figure 19a) to index to the fan control icon. See Figure 30.

Use the UP/DOWN ARROW keys to turn on, off or adjust fan speed. See Figures 19a and 31.

A single “beep” will confirm reception of the command.



Figure 30 - Fan Icon

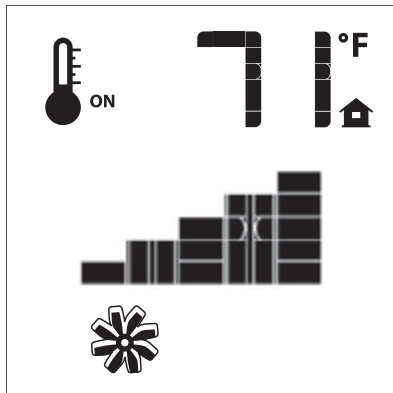

Figure 31 - Fan Speed Control Activated

Continuous Pilot/Intermittent Pilot (CPI/IPI) Selection

With the system in “OFF” position press the MODE key (Figure 19a) to index to the CPI mode icon. See Figures 32 and 36.

Pressing the UP ARROW key will activate the Continuous Pilot Ignition mode (CPI).

Pressing the DOWN ARROW key will return to IPI.

A single “beep” will confirm the reception of the command.

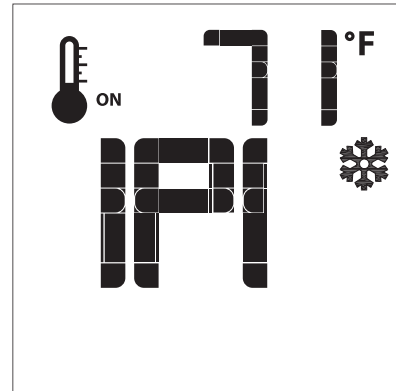

Figure 32



Figure 33

REMOTE CONTROL OPERATION INSTRUCTIONS

Key Lock

This function will lock the keys to avoid unsupervised operation.

To activate this function, press MODE and UP keys at the same time. A Lock and Key icon will appear to the right of the temperature icon.

To deactivate this function, press MODE and UP Keys at the same time.

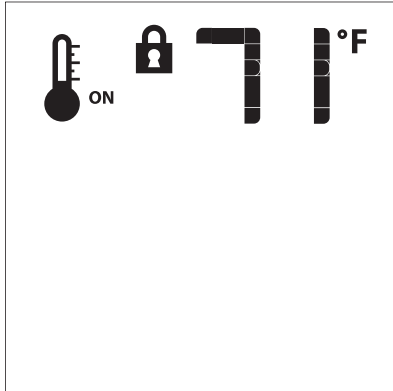

Figure 34

Low Battery Detection

The life span of the remote control batteries depends on various factors: quality of the batteries used, the number of ignitions of the appliance, the number of changes to the room thermostat set point, etc.

When the Transmitter batteries are low, a Battery icon will appear on the LCD display of the Transmitter (**Figure 35**) before all battery power is lost. When the batteries are replaced, this icon will disappear.

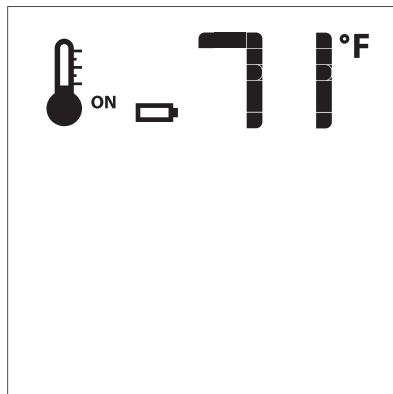

Figure 35

Using the Insert Without a Remote Control

Remove the decorative front and outer surround to access the module. With the ON/OFF rocker switch in the ON position, press with SW1 button on the module. The module will beep 3 times to indicate that it is ready to synchronize with a remote. If no remote is found, the module will enter Manual Mode and the flame and pilot will light. The insert can now be turned ON and OFF with the rocker switch. To enter Remote Mode again, follow the initialization sequence in 15C.

Battery Backup Operation

To operate the insert on Battery Backup, remove the decorative front and outer surround to access the module. Locate the battery holder and install 4 AA batteries into it. The insert will now operate without flame level adjustment or fan.

LOW BATTERY DETECTION MODULE

When the module batteries are low, a double-beep will be emitted when it receives an ON/OFF command. No more commands will be accepted until the batteries are changed or the insert is plugged in.

INSERT MAINTENANCE AND SERVICE

Although the frequency of servicing and maintenance will depend on use and the type of installation, you should have a qualified service technician perform an appliance checkup at the beginning of each heating season. Specific guidelines regarding each appliance maintenance task are listed below.

IMPORTANT: TURN OFF THE GAS BEFORE SERVICING YOUR APPLIANCE.

CLEANING BURNER AND CONTROLS

Frequency: Once annually.

By: Qualified service technician.

Task: Brush or vacuum the control compartment, DXT logs and burner areas surrounding the logs.

CHECKING FLAME PATTERNS, FLAME HEIGHT

Frequency: Periodically.

By: Qualified service technician/Home owner.

Task: Make a visual check of your fireplace's flame patterns. Make sure the flames are steady - not lifting or floating. The flame sensor tips should be covered with flame.



Figure 36 - Correct Flame Pattern

Notice: Natural Gas flames may be taller than the ones shown in the above graphic.

CHECKING VENT SYSTEM

Frequency: Before initial use and at least annually thereafter, more frequently if possible.

By: Qualified service technician/Home owner.

Task: Inspect the external vent cap on a regular basis to ensure that no debris is interfering with the flow of air. Inspect entire vent system for proper function.

CLEANING LOGS (DXT)

Use a soft brush attachment on a vacuum cleaner to gently remove dust or soot deposits from logs and burner.

GLASS CLEANING

It will be necessary to clean the glass periodically. During start-up condensation, which is normal, forms on the inside of the glass and causes lint, dust and other airborne particles to cling to the glass surface. Also initial paint curing may deposit a slight film on the glass. It is therefore recommended that the glass be cleaned two or three times with a non-abrasive household cleaner and warm water (we recommend gas fireplace glass cleaner). After that the glass should be cleaned two or three times during each heating season depending on the circumstances present.

GENERAL GLASS INFORMATION

⚠ WARNING

Do not operate appliance with the glass front removed, cracked or broken. Replacement of the glass should be done by a licensed or qualified service person.

Only glass approved for use by the manufacturer in fireplace may be used for replacement. The glass replacement should be done by a licensed or qualified service person.

⚠ WARNING

1. The use of substitute glass will void all product warranties.
2. Care must be taken to avoid breakage of the glass.
3. Under no circumstances should this appliance be operated without the glass front or with a broken glass front. Replacement of the glass (with gasket) as supplied by the manufacturer should be done by a qualified service person.
4. Do not abuse the glass by striking or hitting the glass.

⚠ WARNING

Do not use abrasive cleaners on glass. Do not attempt to clean glass when glass is hot.

BLOWER REMOVAL/REPLACEMENT

The appliance, when installed, must be electrically connected and grounded in accordance with local codes or, in the absence of local codes, with the current CSA C22.1 Canadian Electrical Code.

U.S. Installations, follow local codes and the National Electrical Code, ANSI/NFPA No. 70.

Should this blower require servicing, the power supply must be disconnected. For rewiring of any replacement components, refer to the wiring diagram on page 25, and the parts list on Pages 36 & 37.

The fireplace insert is equipped with a factory installed blower.

BLOWER REMOVAL/REPLACEMENT INSTRUCTIONS - FROM THE REAR

Servicing or removal of the blower system must be performed by a qualified service person.

If the blower assembly must be replaced, the following steps are recommended for removal:

1. Turn off gas and disconnect the electrical supply.
2. Remove the Decorative Front and Surround from the unit.
3. Carefully pull unit away from the wall to gain access to the venting. Remove venting from the appliance.
4. Pull Insert out of fireplace to gain access to the rear of the appliance.
5. Remove the two screws securing the bottom flange to the firebox. **See Figure 37.**
6. Hand bend the flange so that lays flat. **See Figure 37.**
7. Remove blower from appliance and disconnect the wires at the connectors and discard blower (if applicable).
8. Install the replacement blower, and re-install the insert by reversing above steps.

DXT Unit Shown

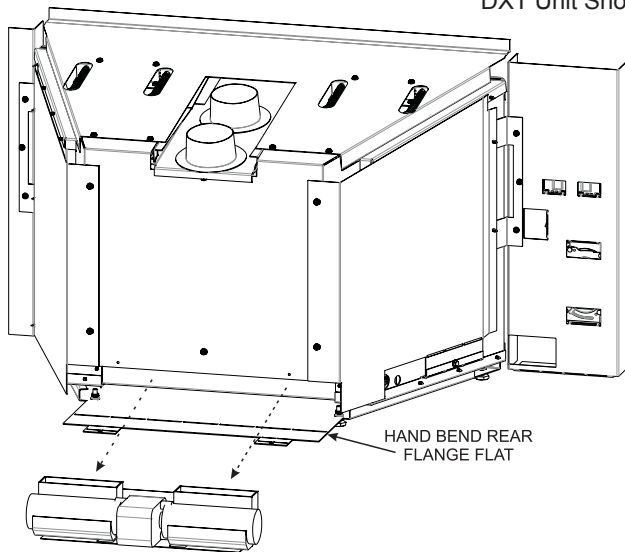

Figure 37

BLOWER REMOVAL/REPLACEMENT INSTRUCTIONS - FROM THE FRONT

Servicing or removal of the blower system must be performed by a qualified service person.

If the blower assembly must be replaced, the following steps are recommended for removal:

1. Turn off gas and disconnect the electrical supply.
2. Remove the Decorative Front and Surround from the unit. Refer to the instructions that came with your Front for more information.
3. If applicable, remove Fireplace Screen. See page 13 for more information.
4. Remove Glass Front Assembly. See page 13 for more information.
5. Remove Logs and Embers material. See pages 15 - 23.
6. Remove the liners. Refer to the instructions that came with your liners for more information.
7. Remove the two screws securing the pilot to the burner. **See Figure 38.**
8. Pull the pilot toward the back of the unit just enough to get it safely out of the way. **See Figure 38.** DO NOT disconnect the pilot.

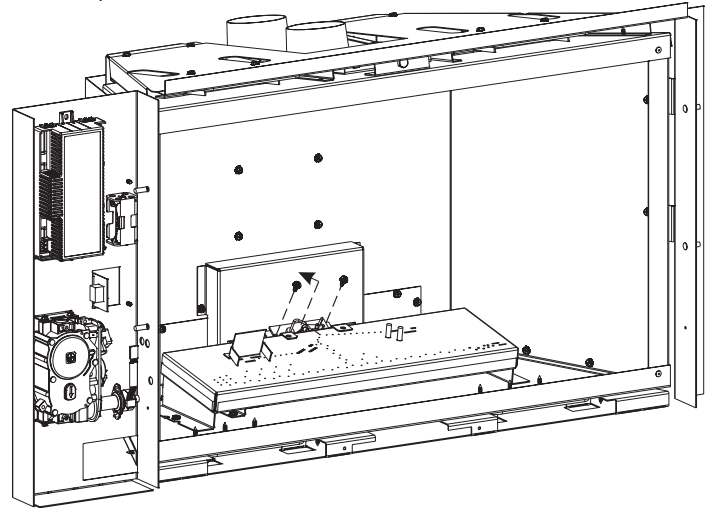
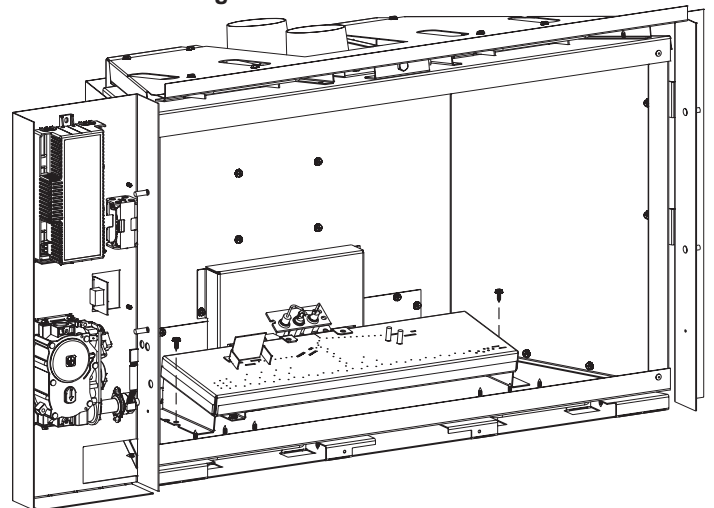

Figure 38

9. Remove the left and right screws securing the burner to the firebox. **See Figure 51.**



BLOWER REMOVAL/REPLACEMENT

Figure 39

14. Slide the burner to the right and lift out. **See Figure 40.**
NOTICE: Sliding the burner to the right ensures that the orifice disengages from the venturi.

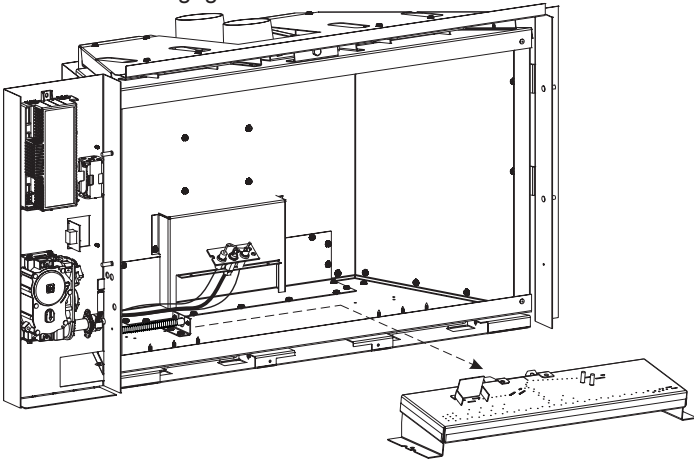

Figure 40

15. Remove the two screws securing the “air box” to the rear of the firebox. Remove the “air box” and set aside. **See Figure 41.**

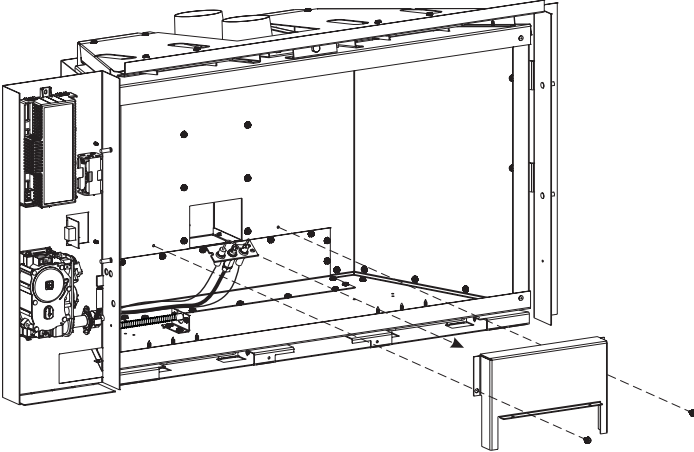

Figure 41

16. Remove the 18 screws securing the blower access panel to the firebox and set aside. Remove the blower access panel and set aside. **See Figure 42.**

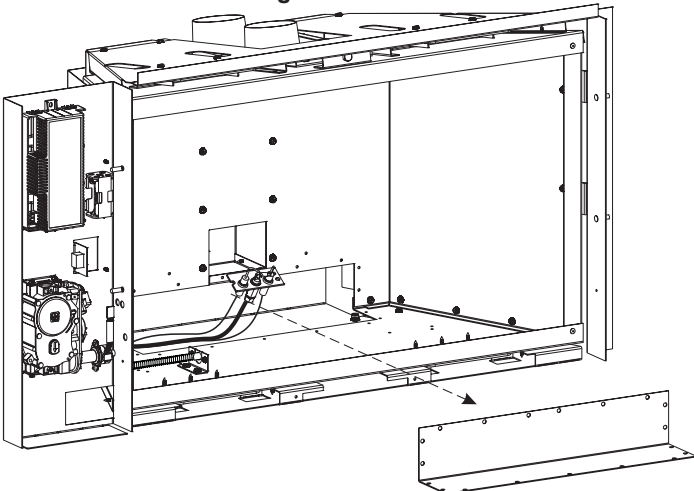

Figure 42

17. Pull blower far enough through the blower access hole to disconnect the wires at the connectors. **See Figure 43.** Once the wires are disconnected, remove blower completely and discard.

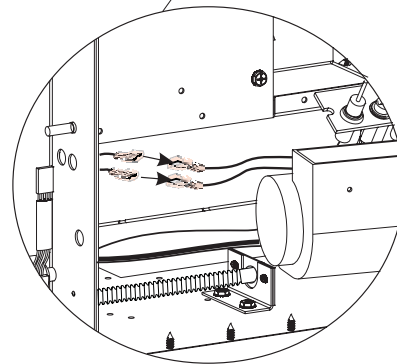
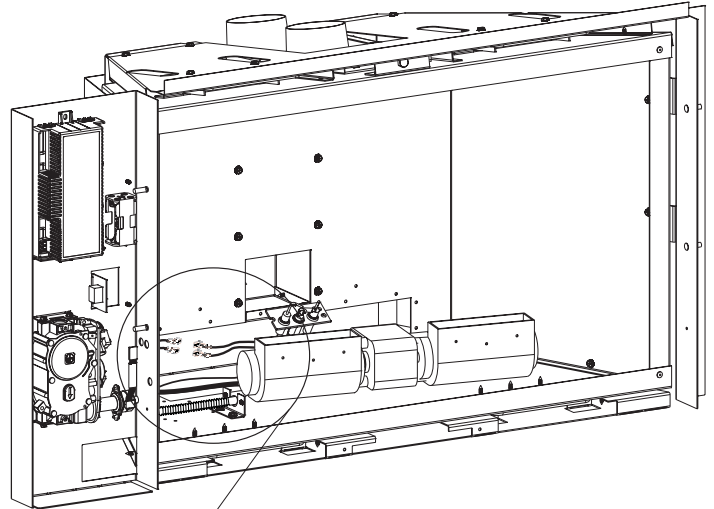

Figure 43

19. Install the replacement blower, and re-install the insert by reversing the above steps.

MASTER PARTS DISTRIBUTOR LIST

To Order Parts Under Warranty, please contact your local Empire dealer. See the dealer locator at www.empirecomfort.com. To provide warranty service, your dealer will need your name and address, purchase date and serial number, and the nature of the problem with the unit.

To Order Parts After the Warranty Period, please contact your dealer or one of the Master Parts Distributors listed below. This list changes from time to time. For the current list, please click on the Master Parts button at www.empirecomfort.com. Please note: Master Parts Distributors are independent businesses that stock the most commonly ordered Original Equipment repair parts for Heaters, Grills, and Fireplaces manufactured by Empire Comfort Systems Inc.

Dey Distributing

1401 Willow Lake Boulevard
Vadnais Heights, MN 55101

Phone: 651-490-9191

Toll Free: 800-397-1339

Website: www.deydistributing.com

Parts: Heater, Hearth and Grills

F. W. Webb Company

200 Locust Street
Hartford, CT 06114

Phone: 860-722-2433

Toll Free: 800-243-9360

Fax: 860-293-0479

Toll Free Fax: 800-274-2004

Websites: www.fwwebb.com & www.victormfg.com

Parts: Heater, Hearth and Grills

East Coast Energy Products

10 East Route 36
West Long Branch, NJ 07764

Phone: 732-870-8809

Toll Free: 800-755-8809

Fax: 732-870-8811

Website: www.eastcoastenergy.com

Parts: Heater, Hearth and Grills

HOW TO ORDER REPAIR PARTS

Parts Not Under Warranty

Parts can be ordered through your Service Person, Dealer, or a Master Parts Distributor. See this page for the Master Parts Distributors list. For best results, the **service person or dealer** should order parts through the distributor. Parts can be shipped directly to the **service person/dealer**.

Warranty Parts

Warranty parts will need a proof of purchase and can be ordered by your Service Person or Dealer. Proof of purchase is **required** for warranty parts.

All parts listed in the Parts List have a Part Number. When ordering parts, first obtain the Model Number and Serial Number from the name plate on your equipment. Then determine the Part Number (**not** the Index Number) and the Description of each part from the following illustration and part list. Be sure to give all this information . . .

Appliance Model Number _____ Part Description _____

Appliance Serial Number _____ Part Number _____

Type of Gas (Propane or Natural) _____

Do not order bolts, screws, washers or nuts. They are standard hardware items and can be purchased at any local hardware store.

Shipments contingent upon strikes, fires and all causes beyond our control.

PARTS LIST

INDEX NO.	PART NUMBER		DESCRIPTION
	DXT30IN	DXT35IN	
1	28939	28939	BRACKET, INJECTOR
2	R7624	R7624	AIR SHUTTER
3	R11530	R11530	VENTURI
4	R10933	R10933	GASKET TUBE BURNER
5	31200	31202	BURNER SUB-ASSEMBLY
6	R11524	R11524	WIRE HARNESS, RECEIVER
7	R11522	R11522	PROFLAME TRANSMITTER
8	28858	28889	TRADITIONAL BASE LINER ASSEMBLY
9	R11538	R11557	GRATE ASSEMBLY
10	28938	28938	PILOT BRACKET
11	R10914	R10914	PILOT ASSEMBLY, NAT
11	R10918	R10918	PILOT ASSEMBLY, LPG
12	28917	28917	PILOT SHIELD
13	31195	31196	GLASS FRAME ASSEMBLY
14	28943	28943	AIR BOX
15	28848	28848	BLOWER ACCESS PANEL
16	31247	31247	BLOWER BRACKET
17	R11534	R11534	BLOWER ASSEMBLY
18	R11564	R11564	SLIDE PLATE ROD
19	28932	28932	LATCH TOOL
20	31190	31190	VENT SLIDE ASSEMBLY
21	R12383	R12383	RECEIVER MODULE
22	R11122	R11122	BATTERY HOLDER, AA WITH SNAP-ON
23	R2522	R2522	SWITCH, ON/OFF
24	R11233	R11233	VALVE - NAT
24	R11234	R11234	VALVE - LPG
25	P243	-	ORIFICE - NAT #36
25	-	P250	ORIFICE - LPG 1.65mm
25	-	P244	ORIFICE - NAT #33
25	P214	-	ORIFICE - LPG #53
26	34595	34596	SCREEN ASSEMBLY
Not Shown	15496	15496	ROCK WOOL

EXPLODED VIEW

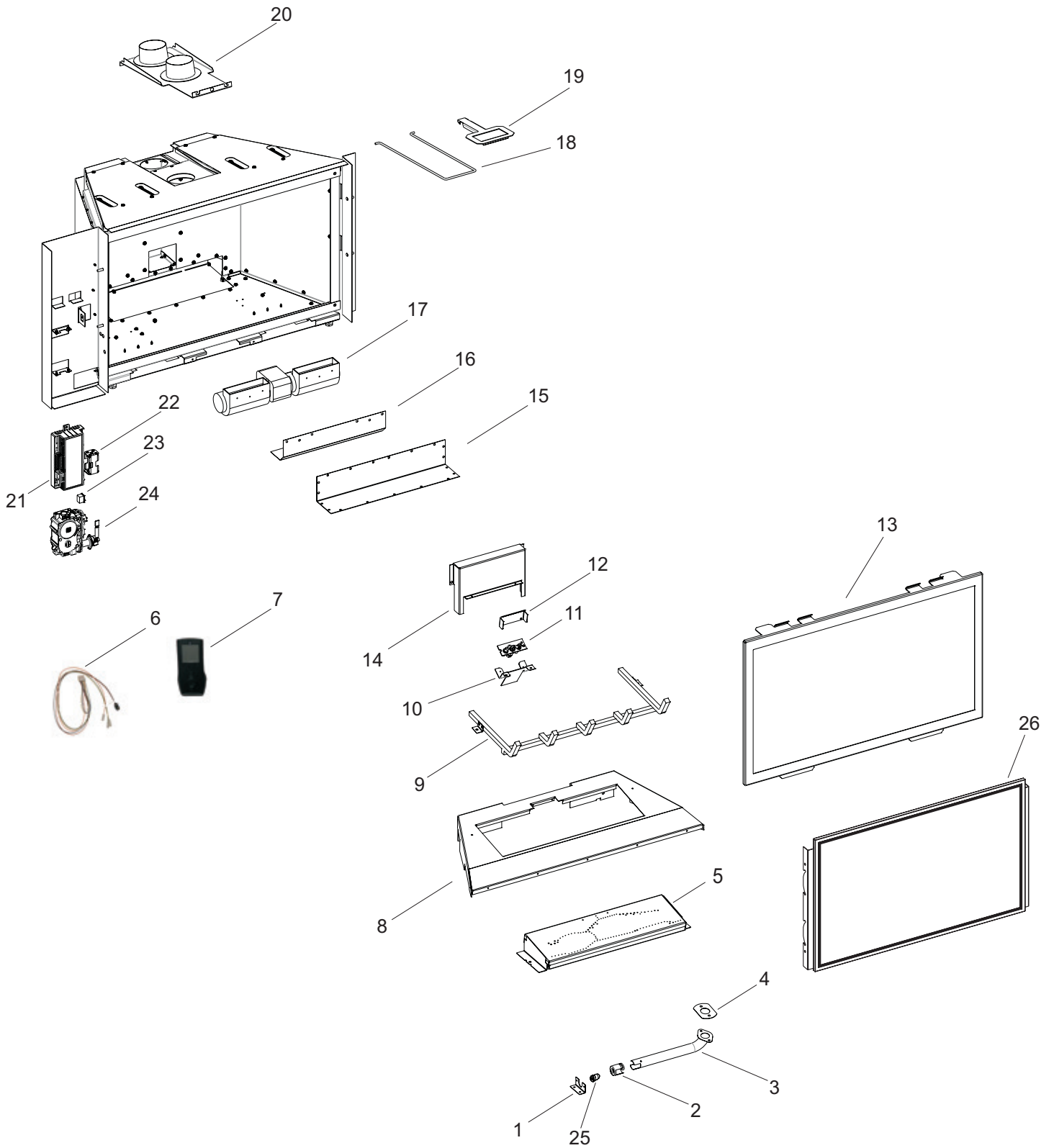

DECORATIVE FRONTS

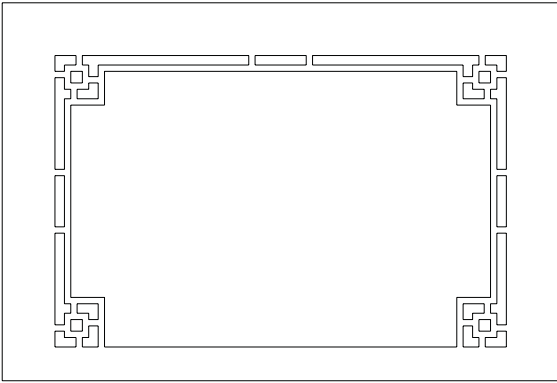

Veranda



Accord

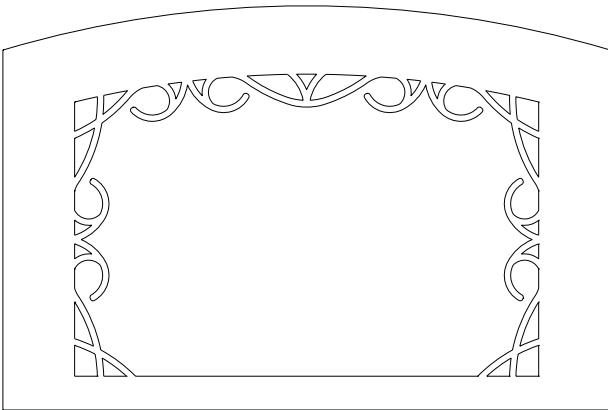

Lafayette

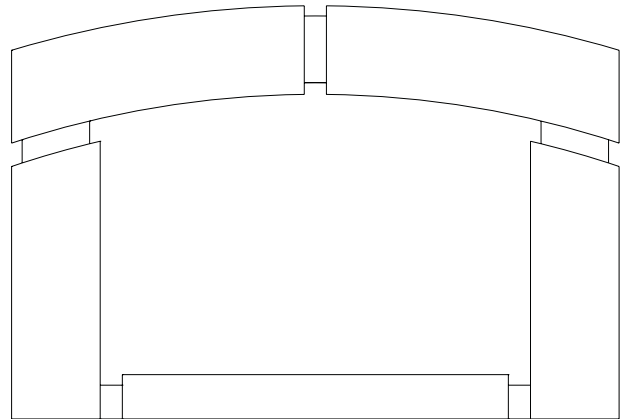

Dunes

IMPORTANT SAFETY INFORMATION

DO NOT OPERATE THIS APPLIANCE WITHOUT GLASS FRONT PANEL INSTALLED

⚠ DANGER: Indicates a hazardous situation which, if not avoided, will result in death or serious injury.

⚠ WARNING: Indicates a hazardous situation which, if not avoided, could result in death or serious injury.

⚠ CAUTION: Indicates a hazardous situation which, if not avoided, could result in minor or moderate injury.

NOTICE: Addresses practices not related to personal injury.

- Children and adults should be alerted to the hazards of high surface temperatures and should stay away to avoid burns or clothing ignition.
- Young children should be carefully supervised when they are in the same room as the appliance.
- Clothing or other flammable material should not be placed on or near the appliance.
- Adequate accessibility clearances for servicing and proper operation should be maintained.
- Under no circumstances should any solid fuels (wood, coal, paper or cardboard etc.) be used in this appliance.
- Keep the area around your appliance clear of combustible materials, gasoline and other flammable vapor and liquids.
- This appliance must not share or be connected to a flue serving a separate solid-fuel burning appliance.
- The flow of combustion and ventilation air must not be obstructed in any way.
- The fireplace insert must be installed in either a masonry or factory-built wood burning fireplace. See page 7 for fireplace opening size requirements.
- Young children should be carefully supervised when they are in the same room as the appliance. Toddlers, young children, and others may be susceptible to accidental contact burns. A physical barrier is recommended if there are at-risk individuals in the house. To restrict access to a fireplace or stove, install an adjustable safety gate to keep toddlers young children, and other at-risk individuals out of the room and away from hot surfaces.
- A barrier designed to reduce the risk of burns from the hot viewing glass is provided with this appliance and shall be installed for the protection of children and other at-risk individuals.
- If the barrier becomes damaged, the barrier shall be replaced with the manufacturer's barrier for this appliance.
- Any safety screen, guard, or barrier removed for servicing an appliance must be replaced prior to operating the appliance.
- Due to high temperatures the appliance should be located out of traffic and away from furniture and draperies.
- The glass front or any part removed for servicing the appliance must be replaced prior to operating the appliance. Work should be done by a qualified service person.
- Keep burner and control compartment clean.
- Vent cap is hot while fireplace is in operation.
- Installation and repair should be done by a **QUALIFIED SERVICE PERSON**. The appliance should be inspected before use and at least annually by a qualified service person. More frequent cleaning may be required due to excessive lint from carpeting, bedding materials, etc. It is imperative that control compartments, burners and circulating air passageways of the appliance be kept clean.
- **DO NOT** put anything around the fireplace insert that will obstruct the flow of ventilation air.
- Maintain clearances in accordance with local installation codes and the requirements of the gas supplier.
- **DO** keep the appliance area clear and free from combustible material, gasoline and other flammable vapors and liquids.
- **DO** examine venting system periodically and replace damaged parts.
- **DO** make a periodic visual check of pilot and burners. Clean and replace damaged parts.

⚠ CAUTION

The glass used in your fireplace insert is ceramic glass. If the glass is cracked or damaged in any way, it should be replaced only with a complete glass frame assembly from Empire. See parts list on Pages 36 and 37 for ordering.

- **DO NOT** use this fireplace insert if any part has been under water. Immediately call a qualified service technician to inspect the heater and to replace any part of the control system and any gas control which has been under water.
- Any safety screen or guard removed for servicing an appliance must be replaced prior to operating the appliance.

SAFETY INFORMATION FOR USERS OF LP-GAS

Propane (LP-Gas) is a flammable gas which can cause fires and explosions. In its natural state, propane is odorless and colorless. You may not know all the following safety precautions which can protect both you and your family from an accident. Read them carefully now, then review them point by point with the members of your household. Someday when there may not be a minute to lose, everyone's safety will depend on knowing exactly what to do. If, after reading the following information, you feel you still need more information, please contact your gas supplier.

LP-GAS WARNING ODOR

If a gas leak happens, you should be able to smell the gas because of the odorant put in the LP-Gas. That's your signal to go into immediate action!

- Do not operate electric switches, light matches, use your phone. Do not do anything that could ignite the gas.
- Get everyone out of the building, vehicle, trailer, or area. Do that IMMEDIATELY.
- Close all gas tank or cylinder supply valves.
- LP-Gas is heavier than air and may settle in low areas such as basements. When you have reason to suspect a gas leak, keep out of basements and other low areas. Stay out until firefighters declare them to be safe.
- Use your neighbor's phone and call a trained LP-Gas service person and the fire department. Even though you may not continue to smell gas, do not turn on the gas again. Do not re-enter the building, vehicle, trailer, or area.
- **Finally**, let the service man and firefighters check for escaped gas. Have them air out the area before you return. Properly trained LP-Gas service people should repair the leak, then check and relight the gas appliance for you.

NO ODOR DETECTED - ODOR FADE

Some people cannot smell well. Some people cannot smell the odor of the chemical put into the gas. You must find out if you can smell the odorant in propane. Smoking can decrease your ability to smell. Being around an odor for a time can affect your sensitivity or ability to detect that odor. Sometimes other odors in the area mask the gas odor. People may not smell the gas odor or their minds are on something else. Thinking about smelling a gas odor can make it easier to smell.

The odorant in LP-gas is colorless, and it can fade under some circumstances. For example, if there is an underground leak, the movement of the gas through soil can filter the odorant. Odorants in LP-Gas also are subject to oxidation. This fading can occur if there is rust inside the storage tank or in iron gas pipes.

The odorant in escaped gas can adsorb or absorb onto or into walls, masonry and other materials and fabrics in a room. That will take some of the odorant out of the gas, reducing its odor intensity.

LP-Gas may stratify in a closed area, and the odor intensity could vary at different levels. Since it is heavier than air, there may be more odor at lower levels. Always be sensitive to the slightest gas odor. If you detect any odor, treat it as a serious leak. Immediately go into action as instructed earlier.

SOME POINTS TO REMEMBER

- Learn to recognize the odor of LP-gas. Your local LP-Gas Dealer can give you a "Scratch and Sniff" pamphlet. Use it to find out what the propane odor smells like. If you suspect that your LP-Gas has a weak or abnormal odor, call your LP-Gas Dealer.
- If you are not qualified, do not light pilot lights, perform service, or make adjustments to appliances on the LP-Gas system. If you are qualified, consciously think about the odor of LP-Gas prior to and while lighting pilot lights or performing service or making adjustments.
- Sometimes a basement or a closed-up house has a musty smell that can cover up the LP-Gas odor. Do not try to light pilot lights, perform service, or make adjustments in an area where the conditions are such that you may not detect the odor if there has been a leak of LP-Gas.
- Odor fade, due to oxidation by rust or adsorption on walls of new cylinders and tanks, is possible. Therefore, people should be particularly alert and careful when new tanks or cylinders are placed in service. Odor fade can occur in new tanks, or reinstalled old tanks, if they are filled and allowed to set too long before refilling. Cylinders and tanks which have been out of service for a time may develop internal rust which will cause odor fade. If such conditions are suspected to exist, a periodic sniff test of the gas is advisable. **If you have any question about the gas odor, call your LP-gas dealer. A periodic sniff test of the LP-gas is a good safety measure under any condition.**
- If, at any time, you do not smell the LP-Gas odorant and you think you should, assume you have a leak. Then take the same immediate action recommended above for the occasion when you do detect the odorized LP-Gas.
- If you experience a complete "gas out," (the container is under no vapor pressure), turn the tank valve off immediately. If the container valve is left on, the container may draw in some air through openings such as pilot light orifices. If this occurs, some new internal rusting could occur. If the valve is left open, then treat the container as a new tank. Always be sure your container is under vapor pressure by turning it off at the container before it goes completely empty or having it refilled before it is completely empty.

WARRANTY

Empire Comfort Systems Inc. warrants this hearth product to be free from defects at the time of purchase and for the periods specified below. Hearth products must be installed by a qualified technician and must be maintained and operated safely, in accordance with the instructions in the owner's manual. This warranty applies to the original purchaser only and is not transferable. All warranty repairs must be accomplished by a qualified gas appliance technician.

Limited Lifetime Parts Warranty – Combustion Chamber, Heat Exchanger, and Factory-Installed Glass

If the combustion chamber, heat exchanger (see parts list) or factory-installed glass fails because of defective workmanship or material, Empire will repair or replace at Empire's option.

**Limited Three-Year Parts Warranty – All Other Components
(Except Remote Controls, Thermostats, Accessories and Replacement Parts)**

Should any part fail because of defective workmanship or material within three years from the date of purchase, Empire will repair or replace at Empire's option..

Limited One-Year Parts Warranty – Remote Controls, Thermostats, Accessories, and Parts

Should any remote control, thermostat, accessory, or other part fail because of defective workmanship within one year from the date of purchase, Empire will repair or replace at Empire's option.

Duties Of The Owner

The appliance must be installed by a qualified installer and operated in accordance with the instructions furnished with the appliance. A bill of sale, cancelled check, or payment record should be kept to verify purchase date and establish warranty period. Ready access to the appliance for service.

What Is Not Covered

Damages that might result from the use, misuse, or improper installation of this appliance.
Travel, diagnostic costs and freight charges on warranted parts to and from the factory.
Claims that do not involve defective workmanship or materials.
Unauthorized service or parts replacements.
Removal and reinstallation cost.
Inoperable due to improper or lack of maintenance.

How To Get Service

To make a claim under this warranty, please have your receipt available and contact your installing dealer. Provide the dealer with the model number, serial number, type of gas, and purchase verification. The installing dealer is responsible for providing service and will contact the factory to initiate any warranted parts replacements. Empire will make replacement parts available at the factory. Shipping expenses are not covered.

If, after contacting your Empire dealer, service received has not been satisfactory, contact: Consumer Relations Department, Empire Comfort Systems Inc., PO Box 529, Belleville, Illinois 62222, or send an e-mail to info@empirecomfort.com with "Consumer Relations" in the subject line.

Your Rights Under State Law

This warranty gives your specific legal rights, and you may also have other rights, which vary from state to state.

APPLIANCE SERVICE HISTORY

Date	Dealer Name	Service Technician Name	Service Performed/Notes

APPLIANCE SERVICE HISTORY

Date	Dealer Name	Service Technician Name	Service Performed/Notes

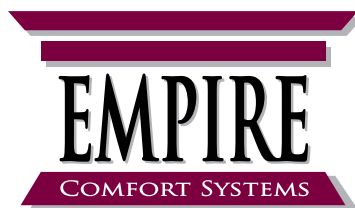

**Empire Comfort Systems Inc.
Belleville, IL**

If you have a general question
about our products, please e-mail
us at info@empirecomfort.com.

If you have a service or repair
question, please contact your dealer.

SINCE 1932

www.empirecomfort.com